

Phono Solar Technology Co., Ltd.

PHONO SOLAR TECHNOLOGY CO., LTD.

Address : No. 1 Xinghuo Rd., Nanjing Hi-tech Zone, Nanjing, China

Tel: +86 25 5863 8000 Fax: +86 25 5863 8009

E-mail: info@phonosolar.com

Website: www.phonosolar.com

Photovoltaic Module
Installation Manual (IEC)

Version: EN-IM-IEC-20230604

Copyright © PHONO SOLAR, 2023



CONTENTS

1. IMPORTANT SAFETY GUIDE
2. PRODUCT IDENTIFICATION
3. MECHANICAL INSTALLATION
4. ELECTRICAL INSTALLATION
5. GROUNDING
6. MAINTENANCE
7. DISCLAIMER OF LIABILITY
8. DISPOSAL OF END OF LIFE PRODUCTS



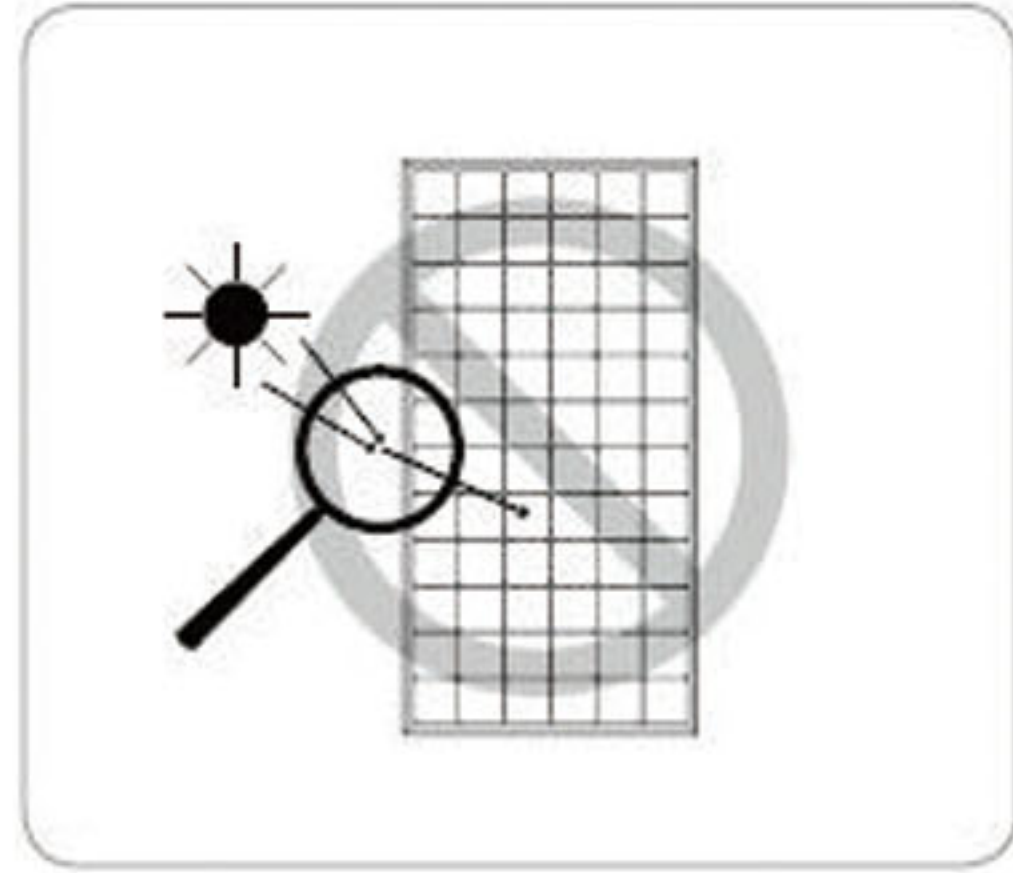

DO NOT use mirrors or magnifiers to concentrate sunlight onto the module.

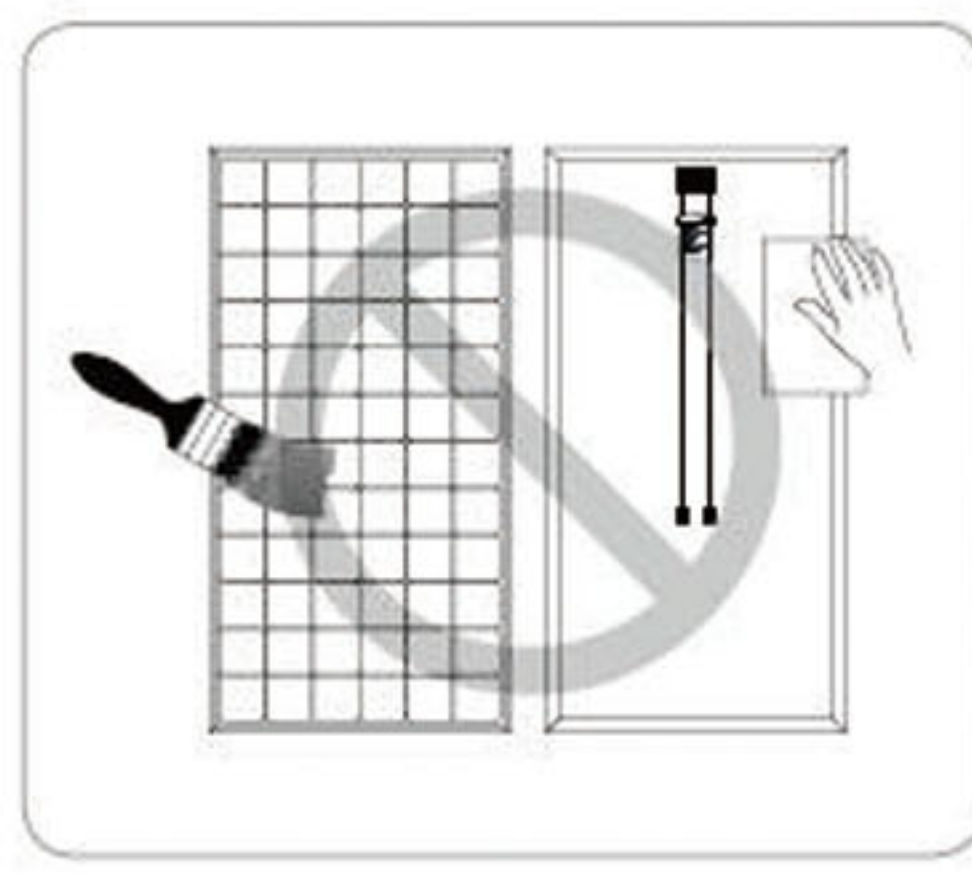

DO NOT paint the module or attach anything on to the back of the module.

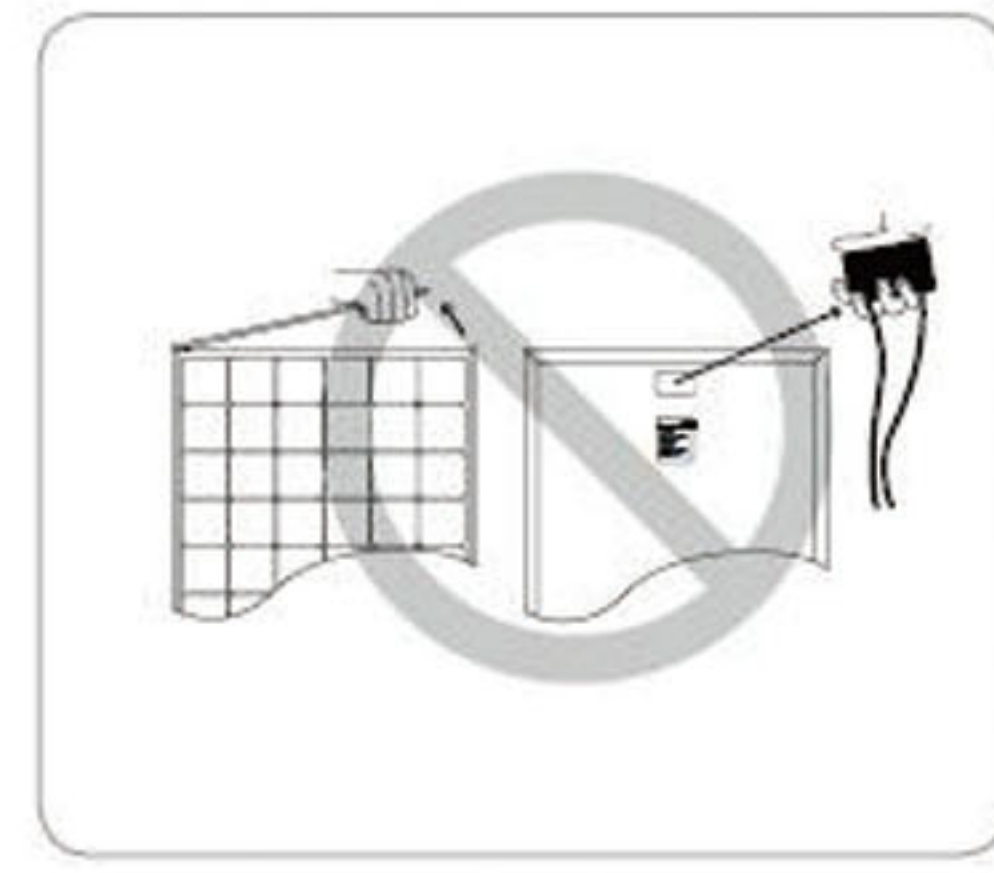

DO NOT attempt to disassemble the modules, and do not remove any attached nameplates or components from the module.

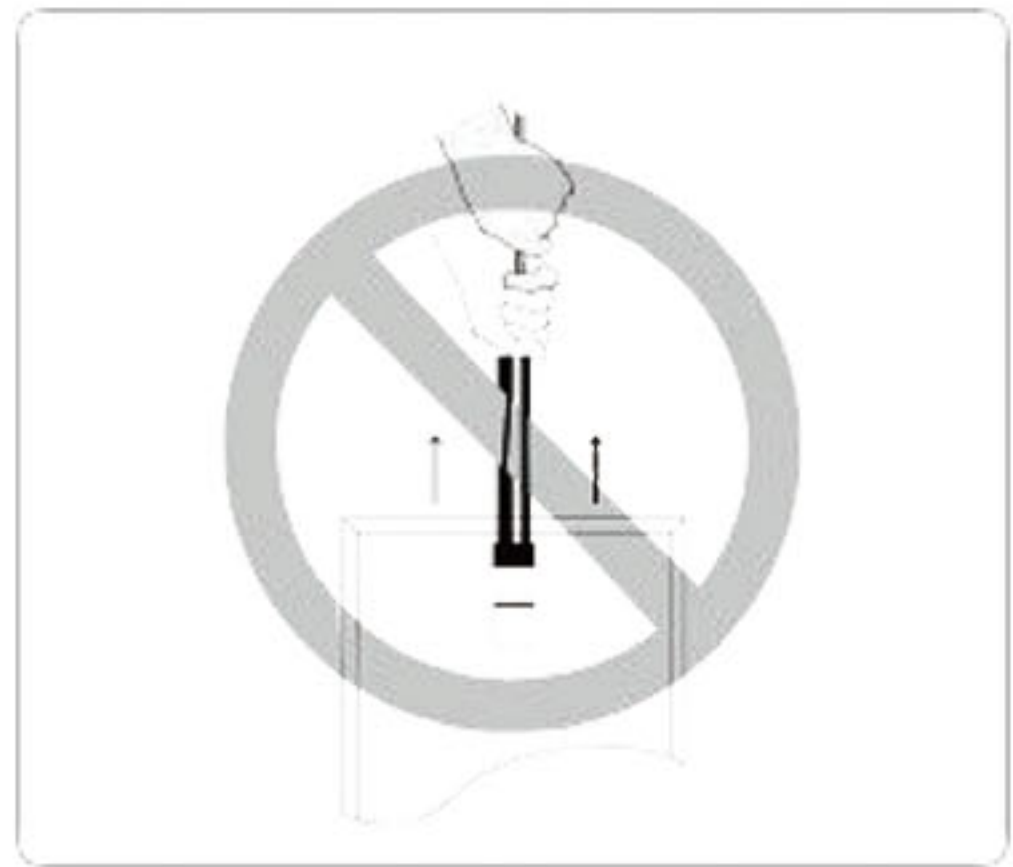

DO NOT lift or move the module by holding the junction box or cable.

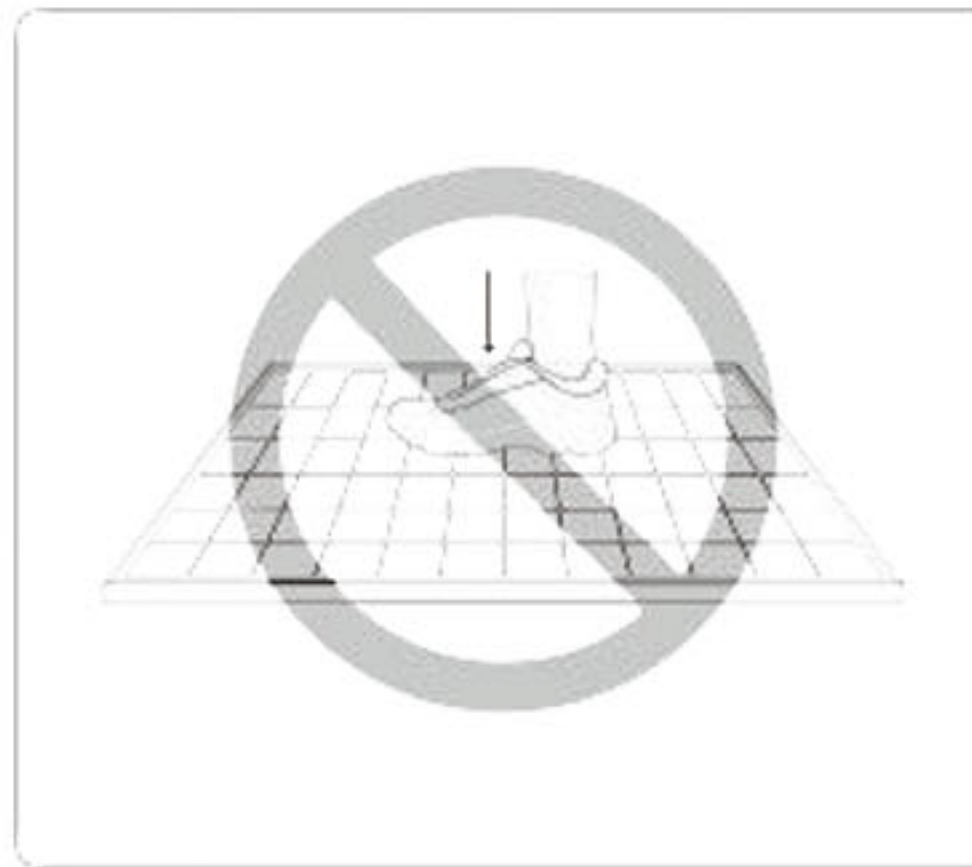

DO NOT place anything on the module or press on the module surface.

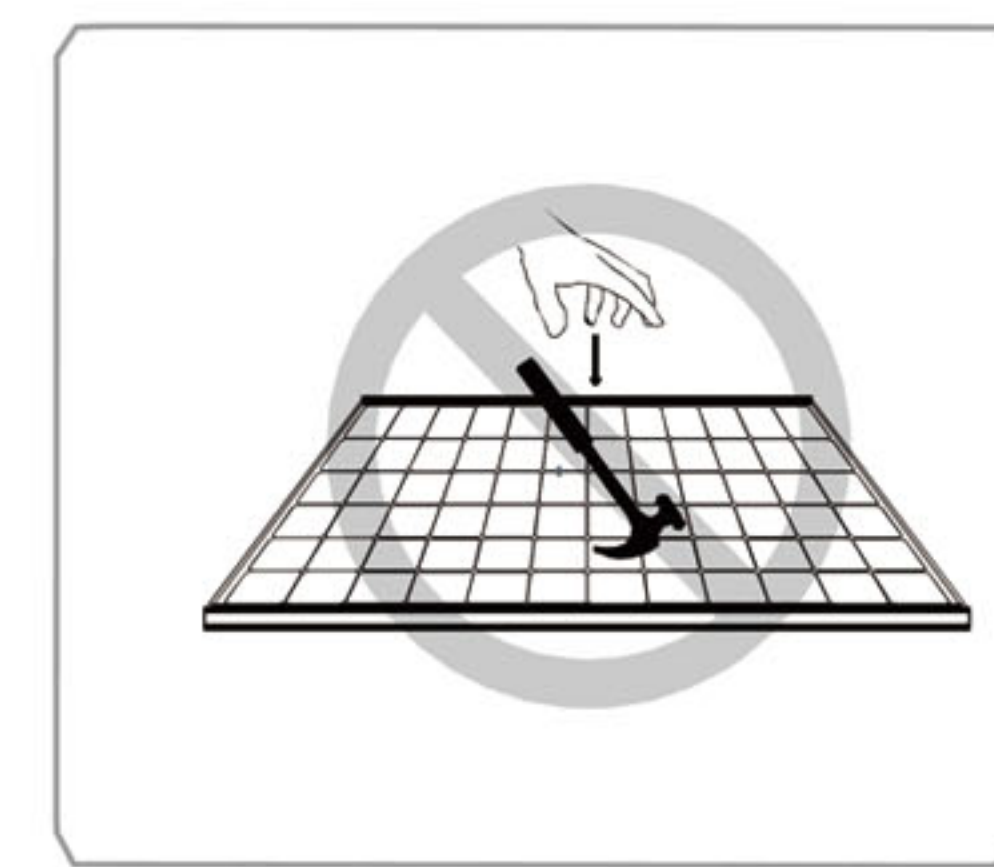

DO NOT drop the module or allow objects to fall on the module.

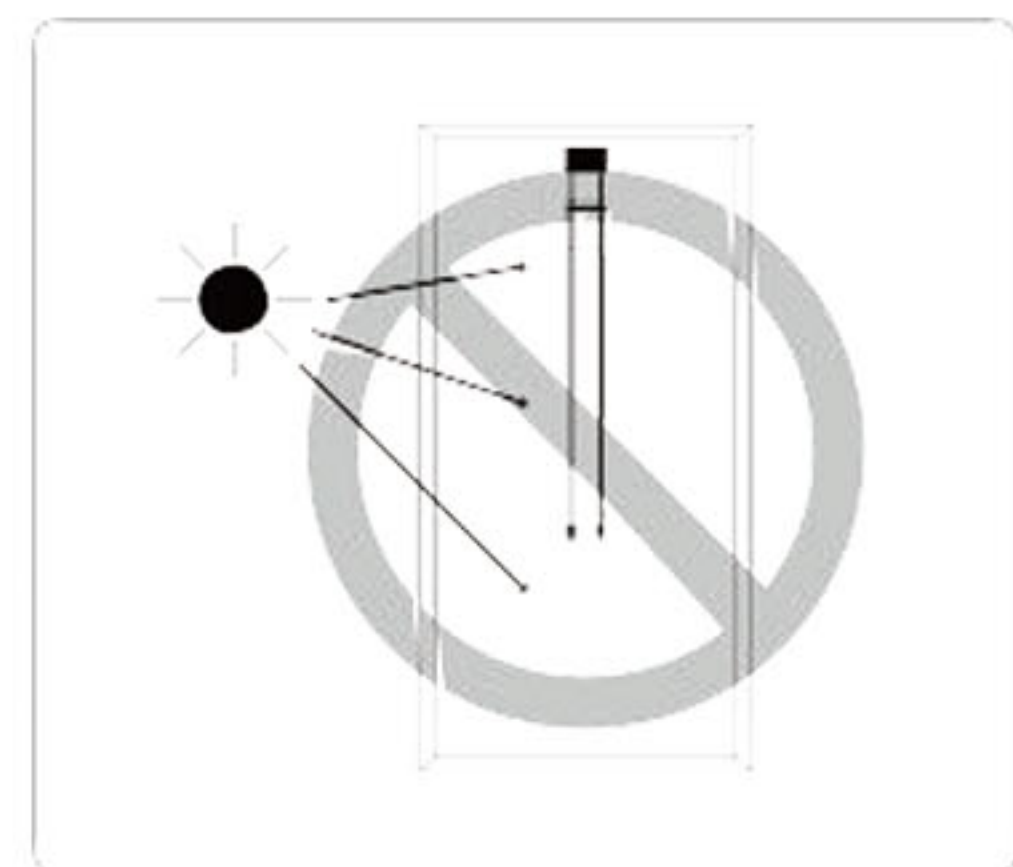

DO NOT expose the back of the module to direct sunlight.

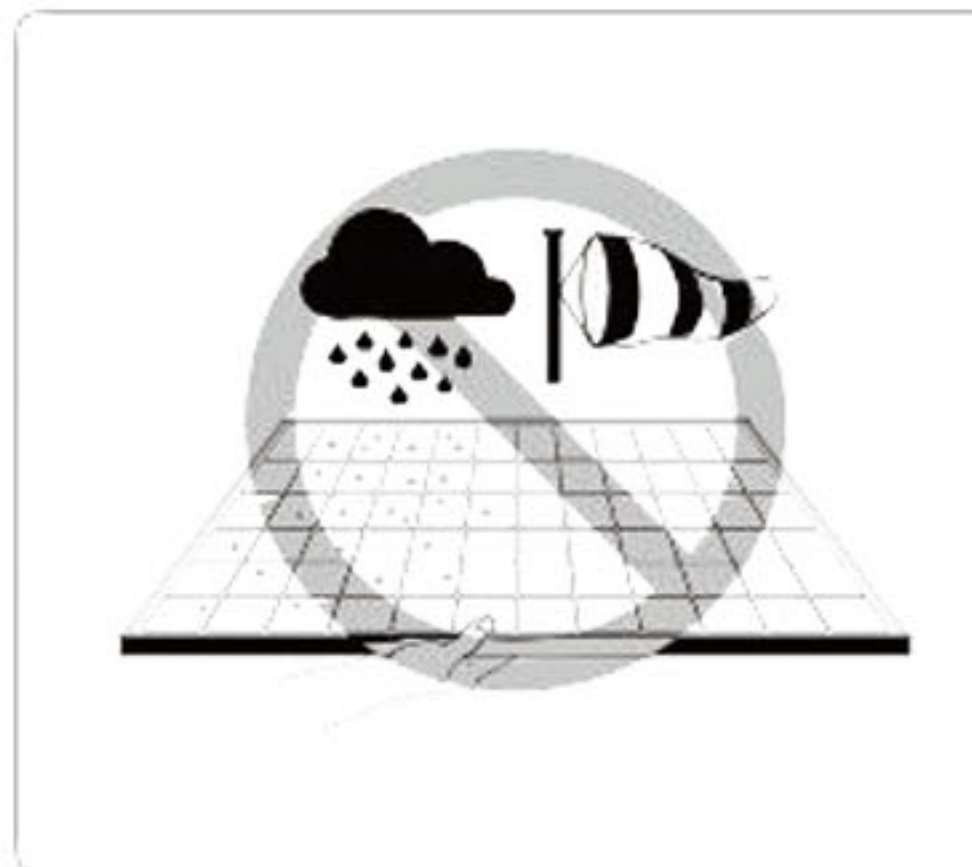

DO NOT install or handle module in wet or strong windy conditions.

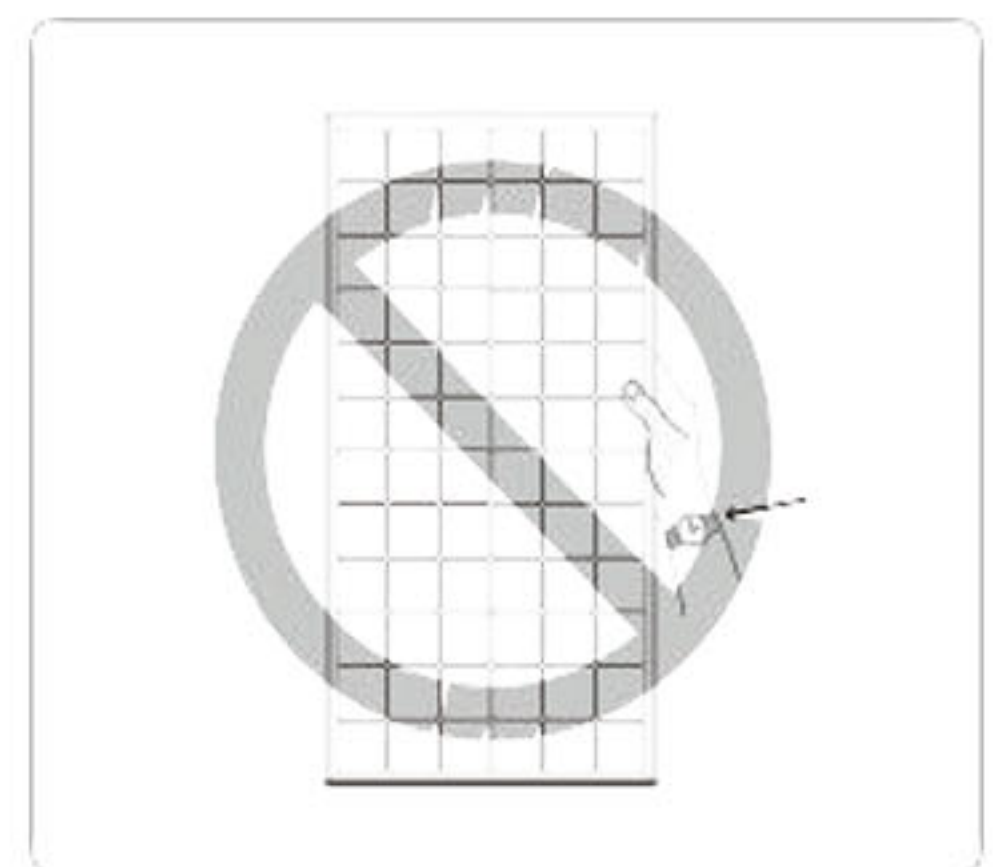

DO NOT wear metal ornaments while handling the module or during the installation.

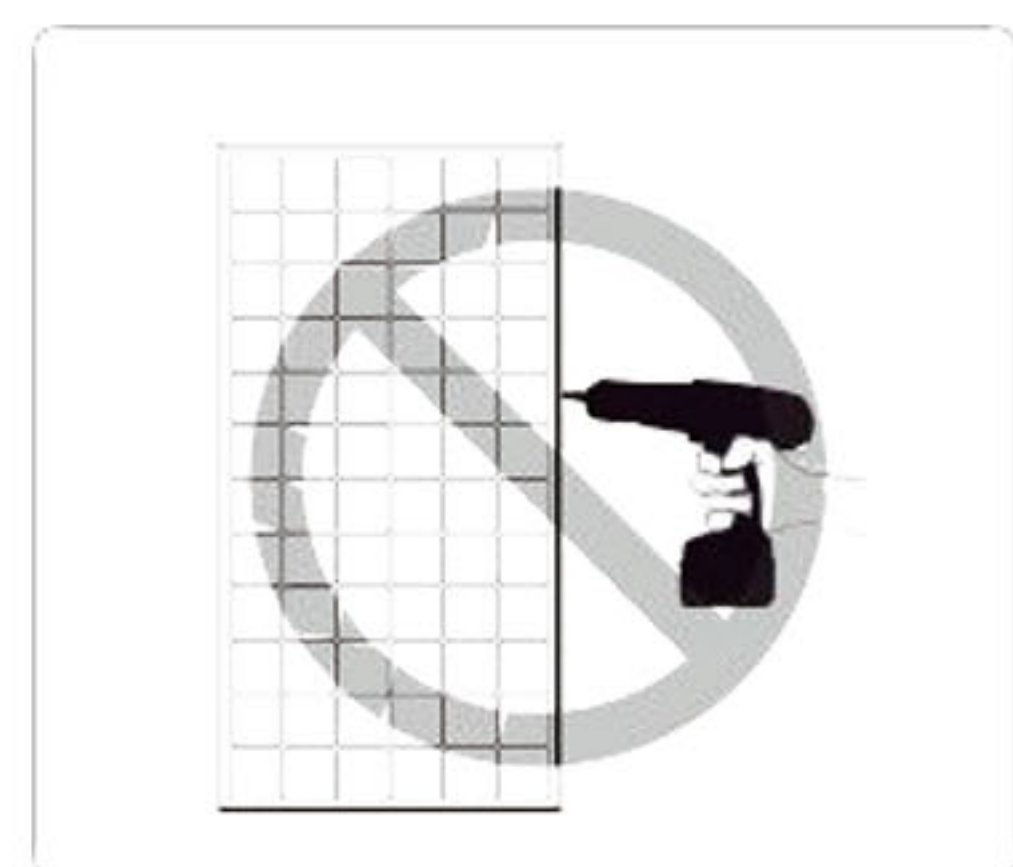

DO NOT drill holes in the frame.

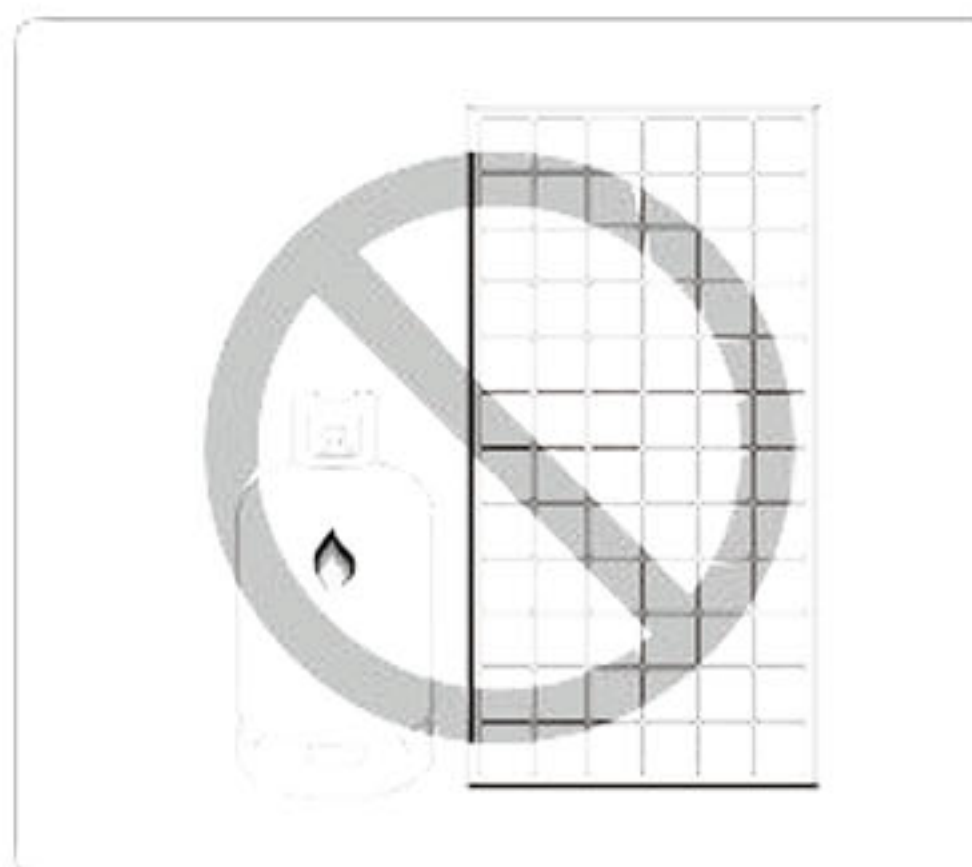

DO NOT use module near equipment or in places where flammable gases may be generated or collected.

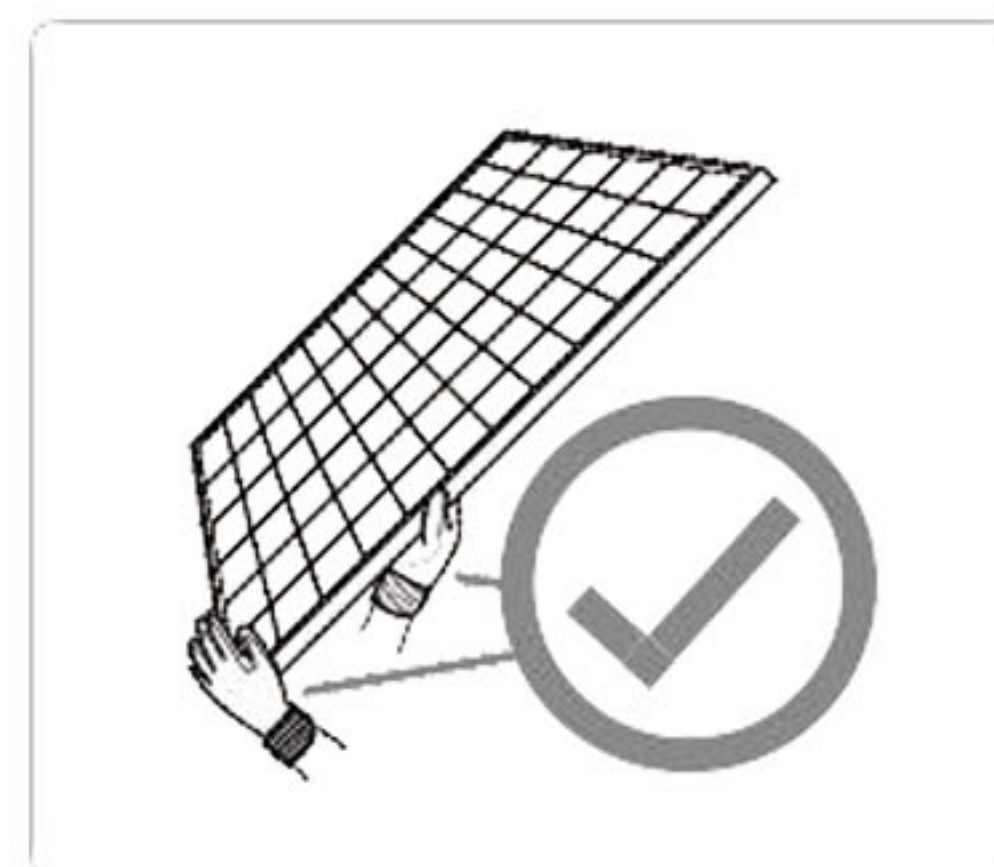

Insulated gloves must be worn while handling the module and during the installation.

1 IMPORTANT SAFETY GUIDE

This manual contains information regarding product identification and the safe installation and maintenance of photovoltaic modules (hereafter referred to as “module”) supplied by PHONO SOLAR TECHNOLOGY CO., LTD. (hereafter referred to as “PHONO SOLAR”). The term “module” can be interpreted as a single module or multiple modules depending on the context.

Installers must already be familiar with the mechanical and electrical requirements for a photovoltaic system. Installers must also read this manual carefully prior to installation. We recommend that you keep this manual in a safe place for future reference and in case of future sale or disposal of the module.

1.1 General Safety

- The installation of a photovoltaic system requires specialized skills and knowledge and must only be carried out by licensed/qualified persons.
- Installers should assume all risks of injury and do everything to avoid potential damages and risks that might occur during installation, including but not limited to, the risks of electric shock.
- PHONO SOLAR modules do not need special cables for connection. All of the modules have permanent junction boxes, cables and connectors.
- Do not use mirrors or magnifiers to concentrate sunlight onto the modules.
- The modules generate DC electrical energy from sunlight. They are designed for outdoor use and can be mounted onto frames on rooftops or in the ground etc.
- Do not paint the module or attach anything on to the back of the module.
- Do not attempt to disassemble the modules, and do not remove any attached nameplates or components from the modules.

1.2 Handling safety

- When handling the module insulated gloves must be worn. Inappropriate transportation and installation may break the module.
- Do not lift or move the module by holding the junction box or cable.
- Do not place anything on the module or press on the module surface.
- Do not drop the module or allow objects to fall on the module.

- Do not expose the back of the module to direct sunlight.
- Do not wear metal ornaments while handling the module.
- Do not install or handle modules in wet or strong windy conditions.

1.3 Installation safety

- Local, regional and state laws and regulations must be adhered to while installing a photovoltaic system. For example, any necessary licenses must be obtained prior to the installation commencing. Regulations around vehicles and ships must also be observed during the installation.
- Observe all safety rules for the other system components, including the cables, connectors, charging controllers, inverter and storage battery etc.
- Do not place the modules near a location where flammable gases are either generated or collected.
- Insulated gloves must be worn during the installation.
- Do not wear metal ornaments during the installation.
- Do not drill holes in the frame.
- Under normal conditions, a module is likely to produce more current and/or voltage than reported under Standard Test Conditions (STC). Accordingly, the values of I_{sc} and V_{oc} marked on the module nameplate should be multiplied by a factor when determining the component voltage ratings, conductor current ratings, fuse sizes, and the size of controllers connected to the photovoltaic system. The exact factor value should be suggested by a licensed/qualified person.
- The live connector may cause fire, spark or lethal shocks even when the modules are not connected.
- Electricity can be generated when the modules are exposed to sunlight, even if they are not connected. It is dangerous to touch 30V DC or higher, so never open the electrical connectors or unplug the electrical connectors while the circuit is under load, and do not touch the live connectors during the installation when the modules are exposed to sunlight.
- Children should be kept away from the photovoltaic system.
- In order to prevent current and voltage generation during installation an opaque board can be used to cover the modules.
- Only use licensed/qualified insulated tools.

- The frame of the modules may be grounded according to local, regional and state safety and electrical standards.
- Only Balance of System (BOS) components that conform with local, regional and state safety electricity standards should be used to avoid affecting module performance and/or module damage.

1.4 Fire Safety

- Consult your local authority for guidelines and requirements for building or structural fire safety.
- Roof constructions and installations may affect the fire safety of a building; an improper installation may create a hazard in the event of a fire.
- Use components such as ground fault circuit breakers and fuses as required by the local authorities.
- Do not use the modules near a location where flammable gases are either generated or collected.

2 PRODUCT IDENTIFICATION

On the back of each module there are 2 labels that provide the following information:

Nameplate: Describes the product type, rated power, rated current, rated voltage, open circuit voltage, short circuit current, all as measured under STC; weight, dimensions etc.; the maximum system voltage of 1000V/1500V DC.



Warning: *The value of V_{oc} multiplied by the number of modules in series should not be bigger than the maximum system voltage marked in the nameplate.*

Barcode: This is used to identify each module. Each module has a unique and traceable serial number in the form of barcode. The barcode of each PHONO SOLAR module has 15 letter/digits.



Warning: *Do not remove the nameplate or barcode. The PHONOSOLAR product warranty will be void if either the module nameplate or barcode is removed.*

3 MECHANICAL INSTALLATION

(Note: All instructions here after are for reference only. A licensed/qualified person or installer must be responsible for the design, installation, mechanical load calculation and security of the photovoltaic system.)

3.1 Select suitable locations for installation

- Select a suitable location for installing the modules.
- PHONO SOLAR recommends that to achieve the best performance the modules should face south in northern latitudes and north in southern latitudes. The exact tilt angle and orientation of mounted modules should be recommended by a licensed/ qualified installer.
- The modules should be completely free of shade at all times.
- Do not place the modules near a location where flammable gases are either generated or collected.

Note1: Saline environments can accelerate the processes of electrical insulation losses and galvanic corrosion, especially when different metals with high electrochemical potential come into contact each other.

In saline environments, based on the distance to seashore, Phono Solar generally classifies coastal PV installation into three different levels:

- From 0 up to 50 meters, Phono Solar does not recommend any installation due to concerns for salt-mist corrosion.
- From 50 to 500 meters, Phono Solar regards this as “Near-Coast” installation requiring adherence to salt-mist corrosion prevention.
- From 500 meters and onwards, Phono Solar estimates standard mounting holes corrosion is minor and only requires annual preventive maintenance.

In “Near-Coast” installation, Phono Solar PV modules must be installed under the following conditions:

- During the installation, do not scratch or break the corrosion-resistant coating (e.g. electroplated layer, oxidized coating, etc.) on the modules and mounting systems.
- Use corrosion-resistant materials (e.g. stainless steel SUS 316) for components (nut, bolt, gasket, etc.) to fixing the modules and mounting systems.

- To avoid possible galvanic corrosion between the aluminum frame and the support structure, mica lamination, or other silicone, or fluoride made gasket shall be interposed between the two metals
- When grounding the module frames, stainless steel hardware must also be used. To prevent salt corrosion to grounding block, fluorocarbon varnish could be sprayed on the grounding block thoroughly to form an anti-corrosion coating (at least 40um thick) or a pad of butyl plaster covering could be placed on the grounding block completely.
- To ensure optimum module performance for near-coast installation, a system maintenance service of every three months is generally recommended and additionally the following maintenance measures shall be taken:
 - Check the frame, mounting system, grounding block and other junction areas for potential signs of corrosion.
 - Clean the frame, mounting system, grounding block and other junction areas from salt and dust accumulation.
 - To repair the rusty areas, apply butyl plaster or fluorocarbon varnish spray to cover the area thoroughly after clean the salt and other dust accumulations around the rusty areas.

Note2 : In environments where ammonia is present, Phono Solar PV modules must be installed under the following conditions:

- When fixing the modules using the 8 mounting slots, all the hardware (washers, screws and nuts) shall be made of stainless steel;
- To avoid possible galvanic corrosion between the aluminum frame and the support structure, PVC washers or neoprene tape shall be interposed between the two metals;
- When grounding the module frames, stainless steel hardware must also be used.

Note3 : If you are planning to use the PV modules where the water damage (Humidity: > 85RH%) may be possible, please consult with Phono Solar technical support first to determine an appropriate installation method and module type, or to determine whether the installation is possible.

3.2 Select suitable mounting rails

Please observe the safety regulations and installation instructions included with the mounting rail. If necessary please contact the supplier directly for further information.

- The modules must be safely set onto the mounting rail. The whole rail supporting the photovoltaic system must be strong enough to resist potential mechanical pressures caused either by wind or snow, in accordance with local, regional and state safety (and other associated) standards.
- Make sure that the mounting rail will not deform or affect the modules when it expands as a result of thermal expansion.
- The mounting rail must be made of durable, anti-corrosive and UV-resistant materials.

PHONO SOLAR modules can be mounted using two methods:

Screw fitting: Use corrosion-proof screws in the existing installing holes in the module frame. Each module has 8 mounting holes for securing the module on the mounting rail. The module frame must be attached to a mounting rail using M8 corrosion-proof screws together with spring washers and flat washers in symmetrical locations on the module. The applied torque should be 16~20Nm. Please find detailed mounting information in the below illustration:

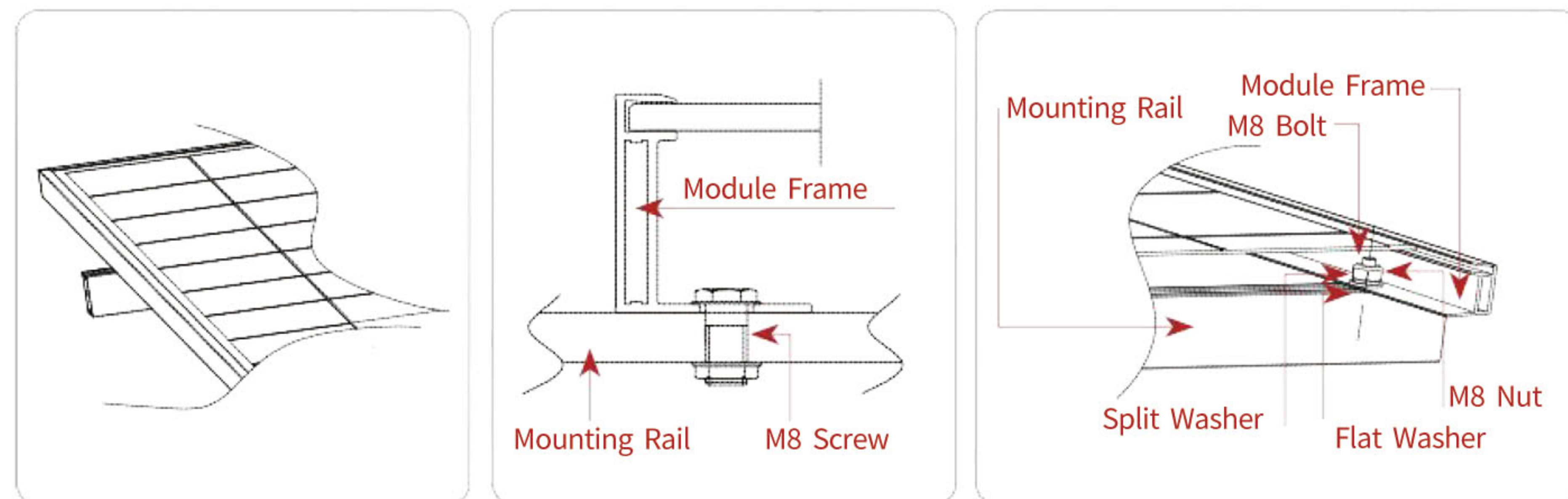

Module installed using Screw Fitting method

Figure 1

Clamp fitting: Using suitable module clamps on the LONG side of the module frame to mount the modules is “portrait orientation” mode, while on the SHORT side of the module frame is “landscape orientation” mode.

The module clamps should not come into contact with the front glass and must not deform the module frame. Avoid any shadowing effects from the module clamps. The module frame can not be modified under any circumstances. Regardless of the orientation chosen, at least 4 clamps must be used on each module. Depending on the local wind and snow loads, additional clamps may be required. The applied torque should be about 16~20Nm. Please find detailed mounting information in the below illustration:

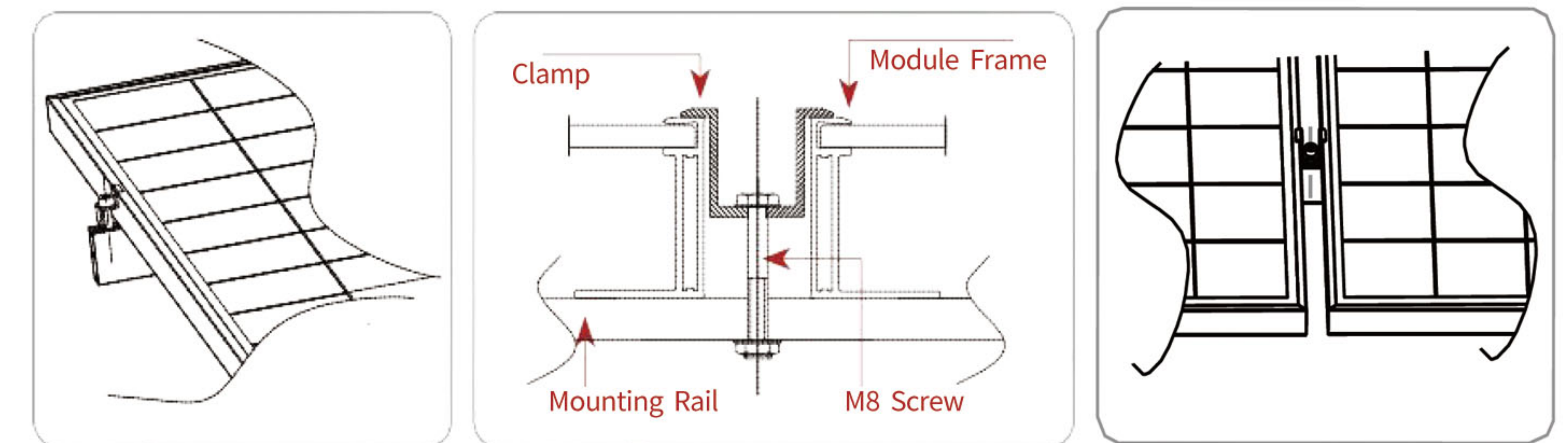

Module installed using Clamp Fitting method

For module based on 156/158/166mm cell ,
the minimum recommended length for each clamp is 50 mm ;
For module based on 182mm cell ,
the minimum recommended length for each clamp is 60 mm.

Figure 2

Select the appropriate installation method depending on the load (see below for more detailed information).

V Type module (182mm)	
Type	PSXXM6H-18/VH; PSXXM6-18/VH
Size (mm)	1724mm × 1134mm × 30/35mm; 1722mm × 1134mm × 30/35mm; 1718mm × 1134mm × 30/35mm

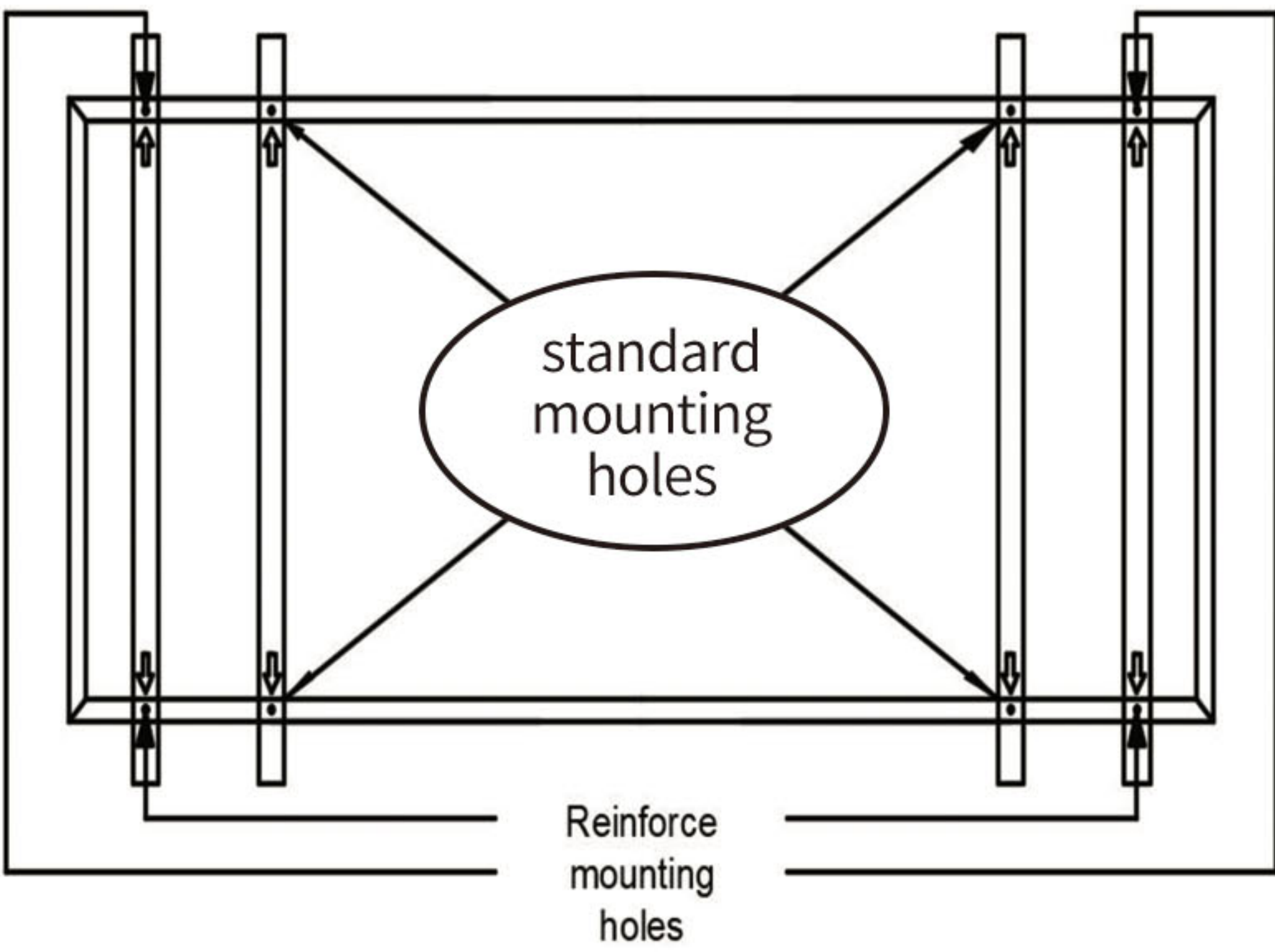
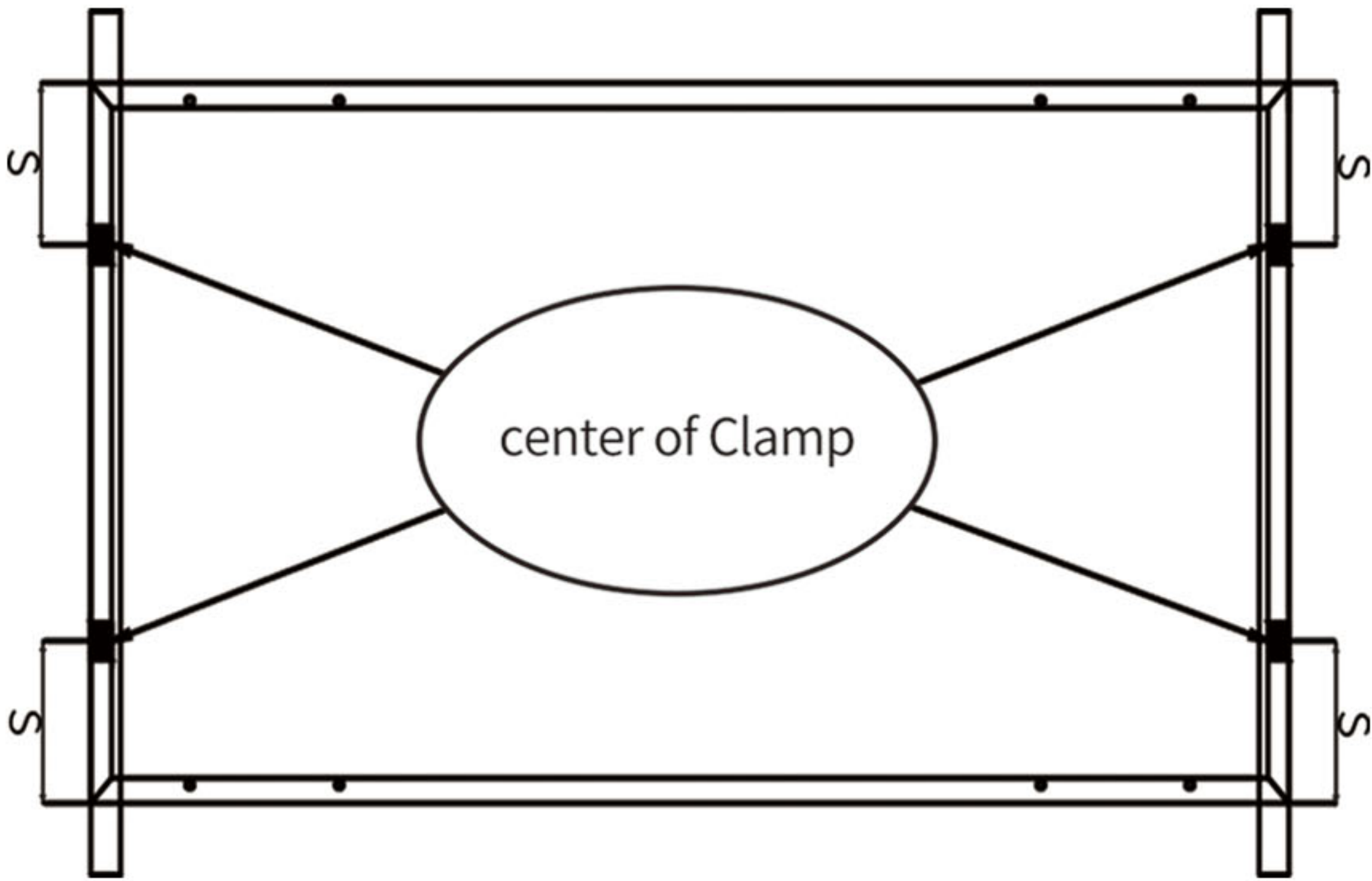
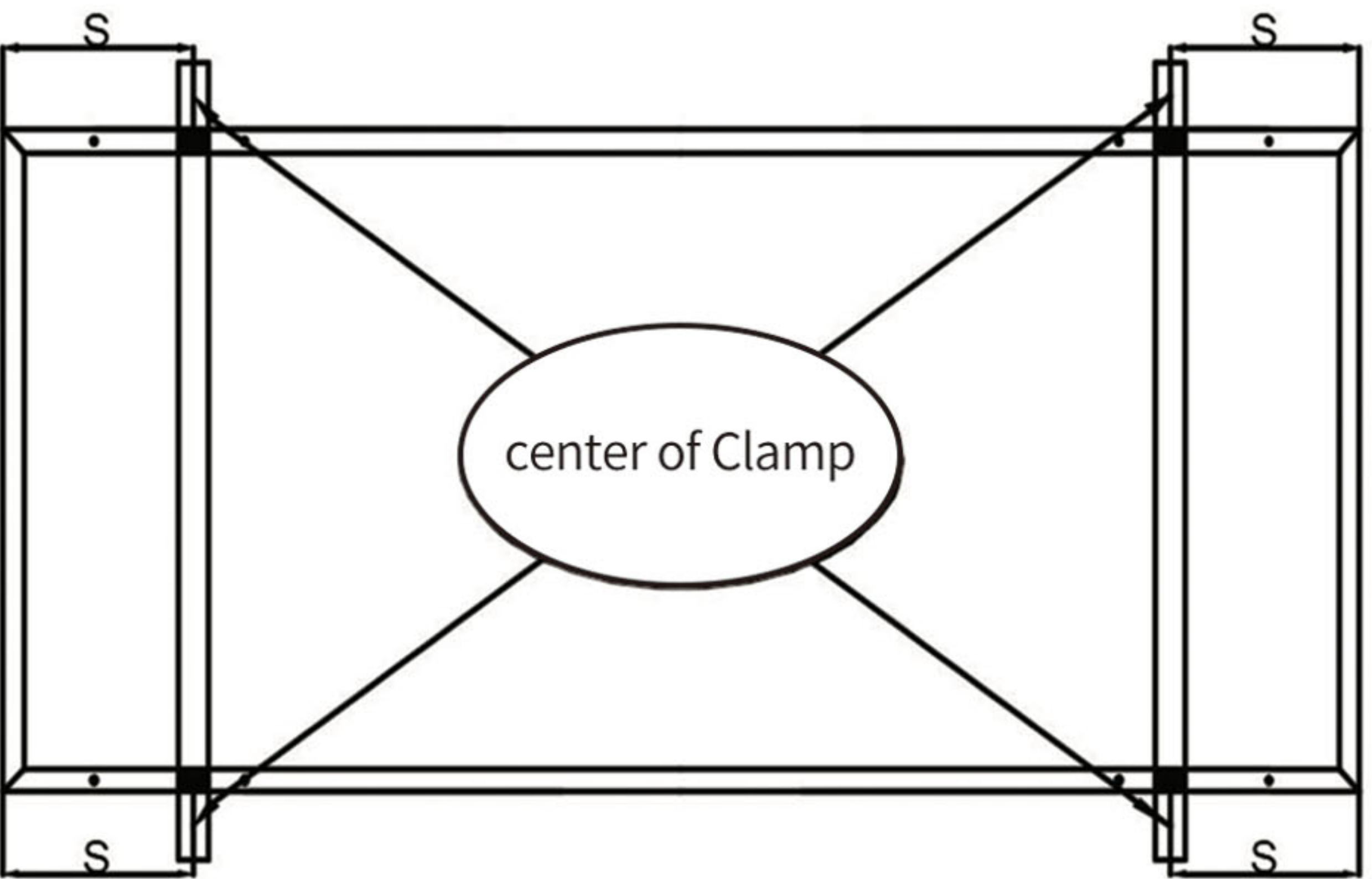
Installation	Mounting System	Clamping System	
	Maximum Load: Uplift load ≤ 2400 Pa Downforce load ≤ 5400 Pa	Maximum Load: Uplift load ≤ 1600 Pa Downforce load ≤ 2000 Pa	Maximum Load: Uplift load ≤ 2400 Pa Downforce load ≤ 5400 Pa
	Use standard mounting holes and reinforce mounting holes	Use four clamps 0 mm<S<200mm ■ Permissible Clamp Range	Use four clamps 380 mm<S<480mm ■ Permissible Clamp Range
			
	The guide rail should be installed perpendicular to the long side of the frame	The guide rail should be installed perpendicular to the long side of the frame	The guide rail should be installed perpendicular to the long side of the frame

VG Type module (182mm)	
Type	PSXXM7GFH-18/VH; PSXXM7GF-18/VH; PSXXM8GFH-18/VH; PSXXM8GF-18/VH; PSXXM7GFH-18/VNH PSXXM8GF-18/VNH; PSXXM8GFH-18/VNH
Size (mm)	1724mm × 1134mm × 30/35mm; 1722mm × 1134mm × 30/35mm; 1718mm × 1134mm × 30/35mm

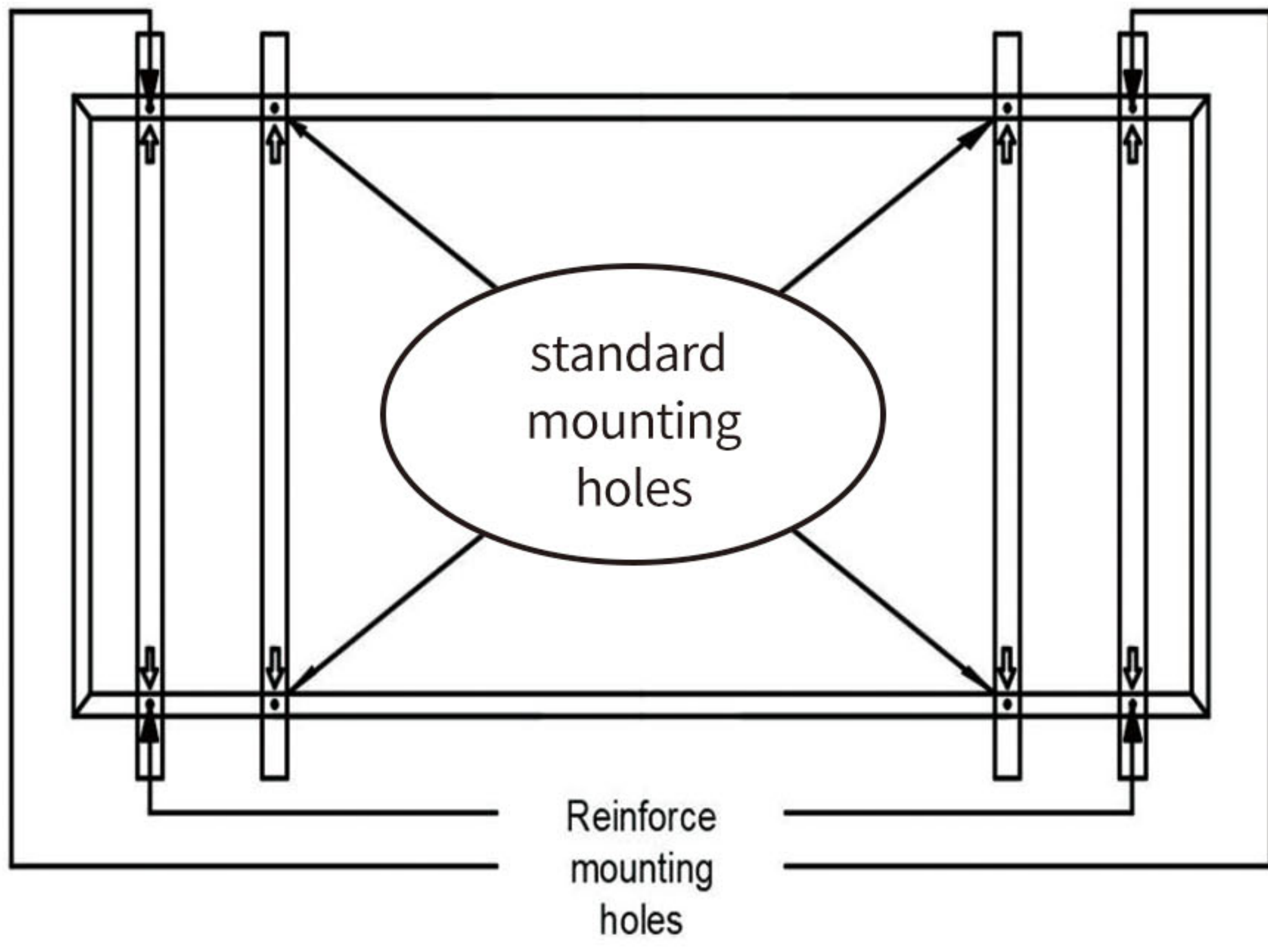
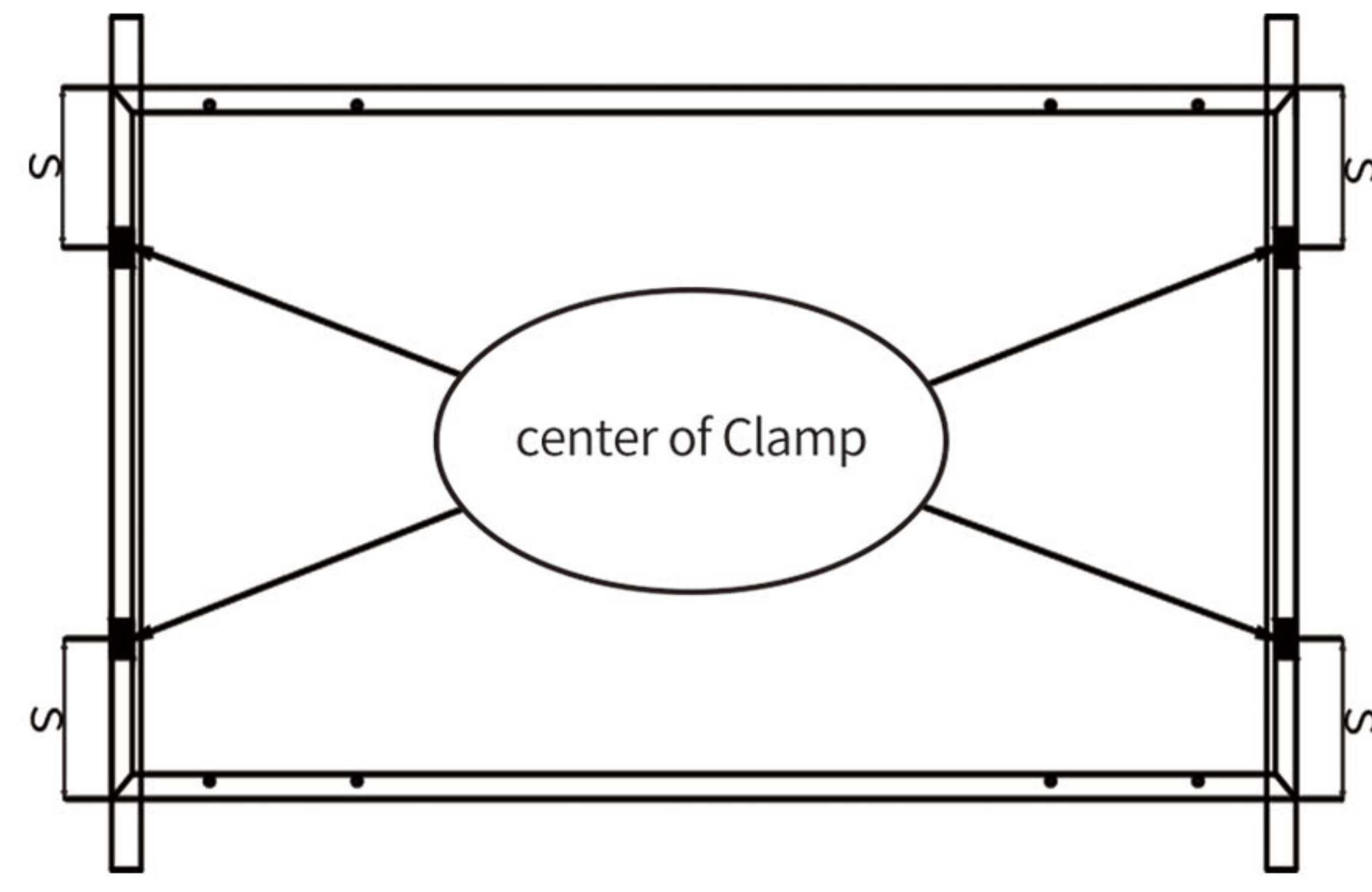
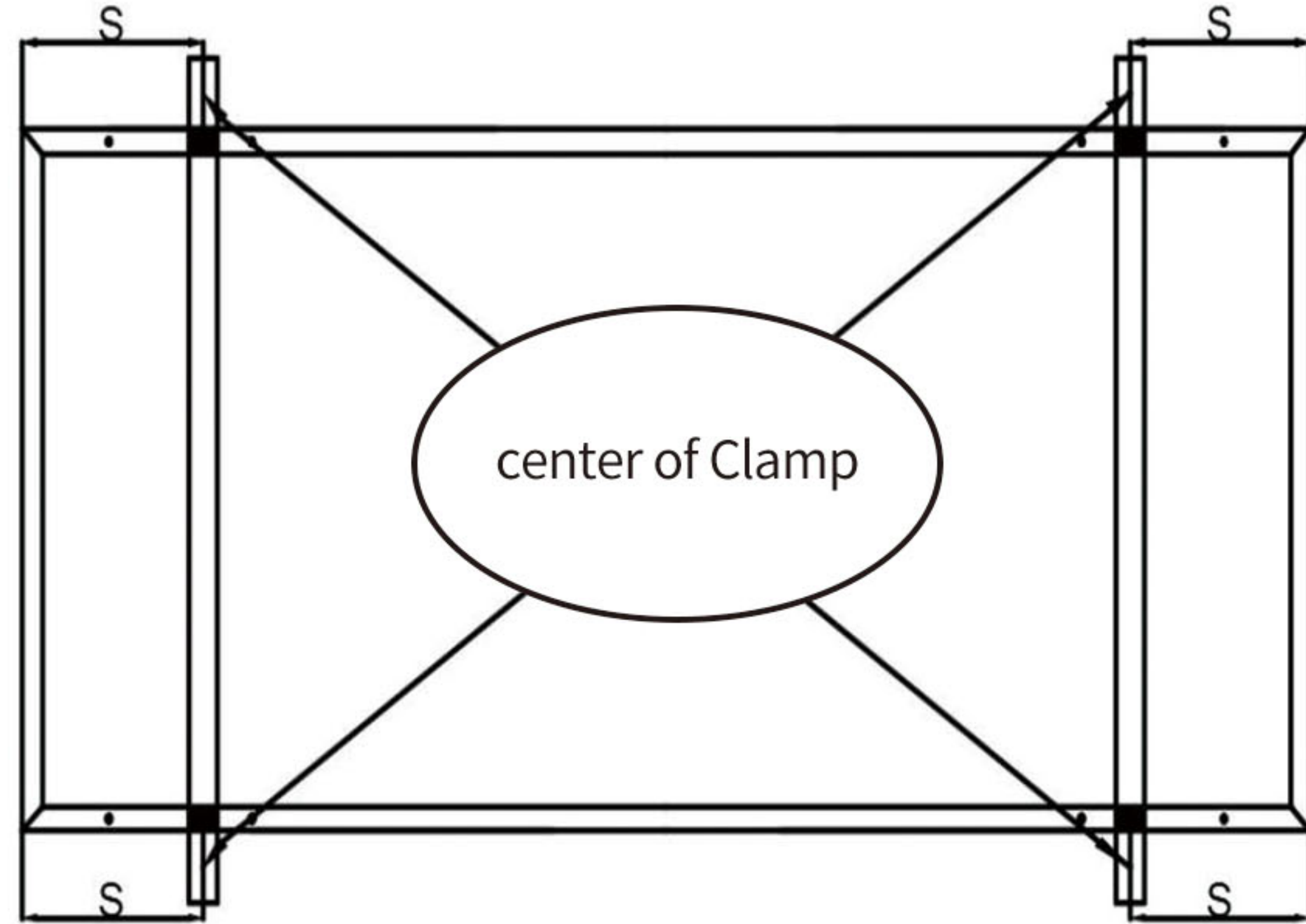
Installation	Mounting System	Clamping System	
	Maximum Load: Uplift load ≤ 2400 Pa Downforce load ≤ 5400 Pa	Maximum Load: Uplift load ≤ 1600 Pa Downforce load ≤ 2000 Pa	Maximum Load: Uplift load ≤ 2400 Pa Downforce load ≤ 5400 Pa
	Use standard mounting holes and reinforce mounting holes	Use four clamps 0 mm<S<200mm ■ Permissible Clamp Range	Use four clamps 380 mm<S<480mm ■ Permissible Clamp Range
	 <p style="text-align: center;">standard mounting holes</p> <p style="text-align: center;">Reinforce mounting holes</p>	 <p style="text-align: center;">center of Clamp</p>	 <p style="text-align: center;">center of Clamp</p>
	The guide rail should be installed parallel position to the long side of the frame	The guide rail should be installed parallel position to the long side of the frame	The guide rail should be installed perpendicular to the long side of the frame

U Type module (156.75mm , 158.75mm)	
Type	PSXXXP-20/U; PSXXXP-20/UH; PSXXPH-20/U; PSXXPH-20/UH; PSXXM-20/U; PSXXMH-20/U; PSXXMGF-20/U; PSXXMGF-20/UH; PSXXMGF-20/U; PSXXMGF-20/UH; PSXXM-20/UH; PSXXMH-20/UH; PSXXM1-20/U; PSXXM1-20/UH; PSXXM1-20/UH; PSXXM1-20/UH
Size (mm)	1686mm × 1000mm × 35/40mm; 1684mm × 998mm × 30mm ; 1675mm × 992mm × 35/40/45mm ; 1666mm × 1000mm × 35/40mm; 1664mm × 998mm × 20/30mm; 1640mm × 992mm × 35/40/45mm

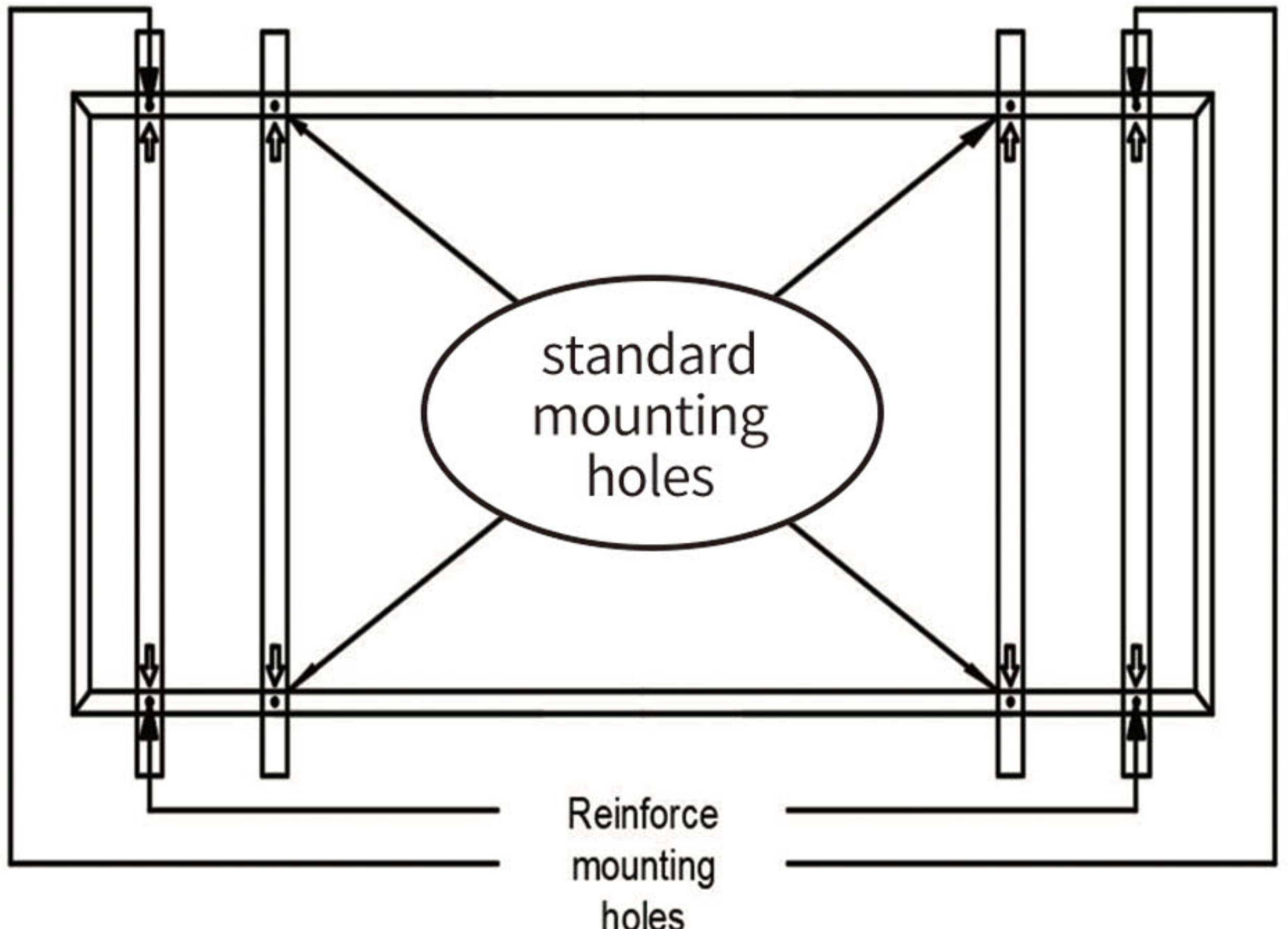
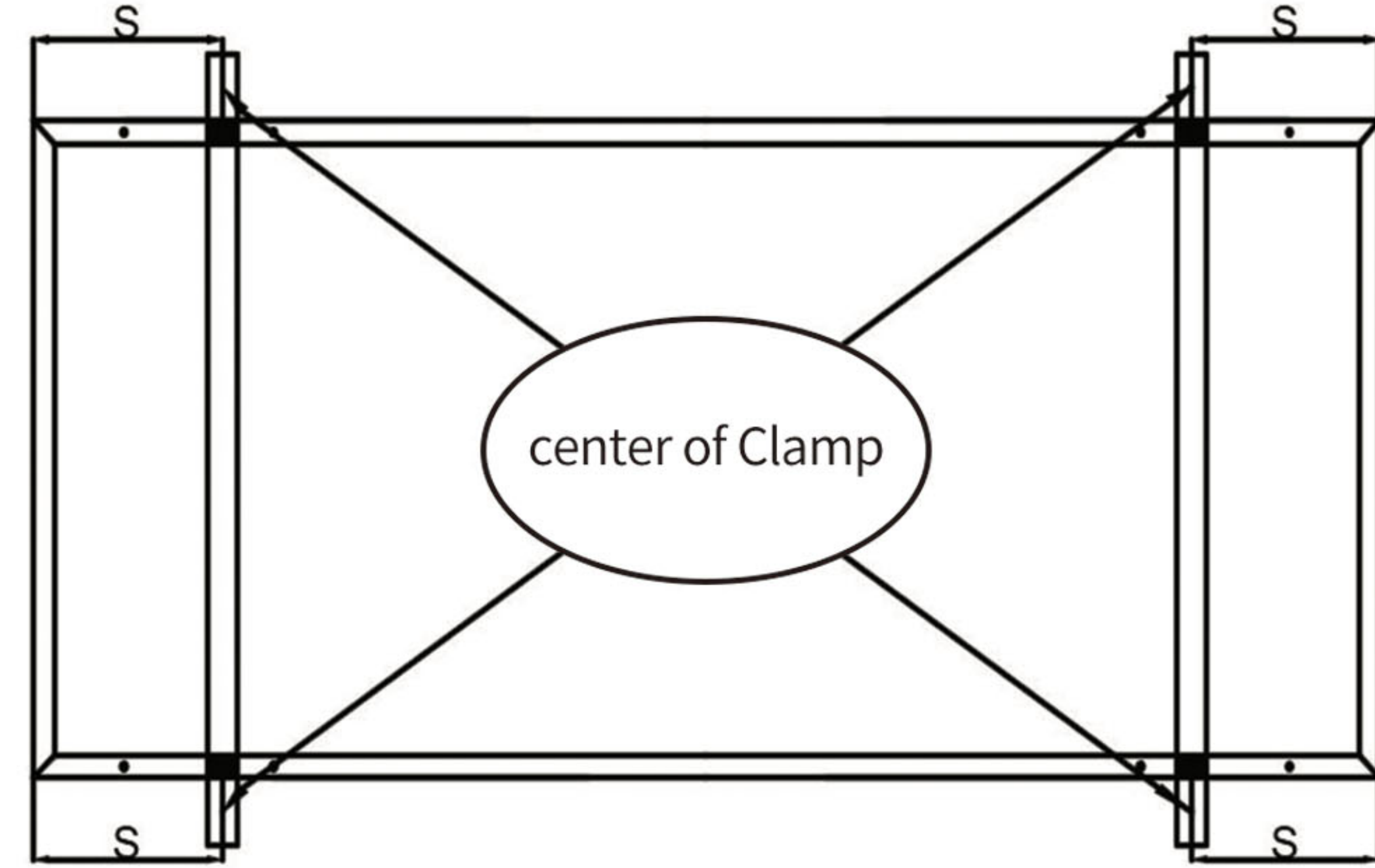
Installation	<h3>Mounting System</h3>	<h3>Clamping System</h3>
	Maximum Load: Uplift load \leq 2400 Pa Downforce load \leq 5400 Pa	Maximum Load: Uplift load \leq 2400 Pa Downforce load \leq 5400 Pa
	Use standard mounting holes and reinforce mounting holes	Use four clamps $205\text{mm} < S < 455\text{mm}$ ■ Permissible Clamp Range
		
	The guide rail should be installed perpendicular to the long side of the frame	The guide rail should be installed perpendicular to the long side of the frame

U Type module (166mm)	
Type	PSXXM4H-20/UH; PSXXM4-20/UH; PSXXM5H-20/UH; PSXXM5-20/UH
Size (mm)	1776mm × 1052mm × 30/35mm; 1764mm × 1040mm × 30/35mm; 1762mm × 1039mm × 30/35mm; 1756mm × 1039mm × 30/35mm; 1755mm × 1038mm × 30/35mm

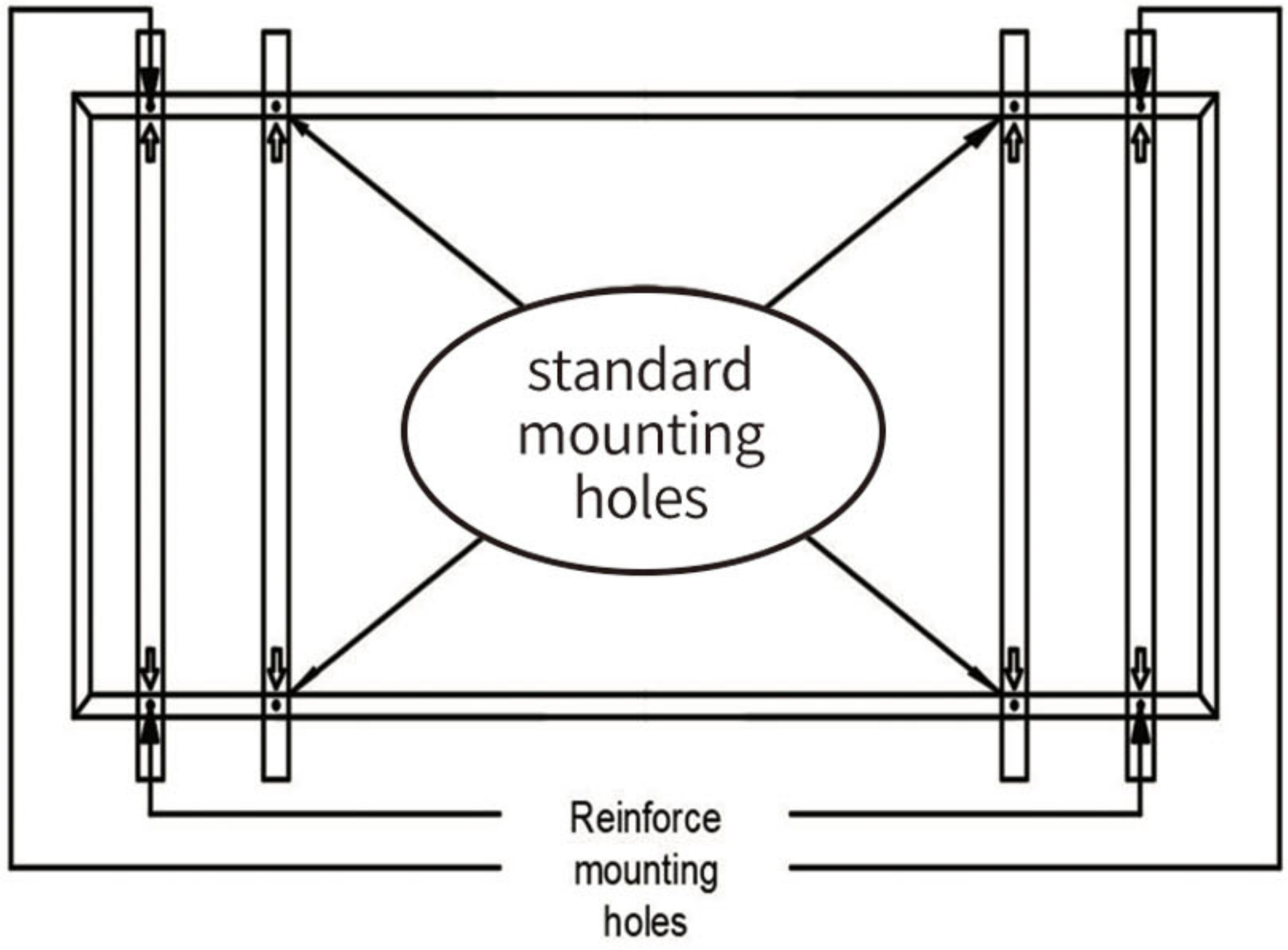
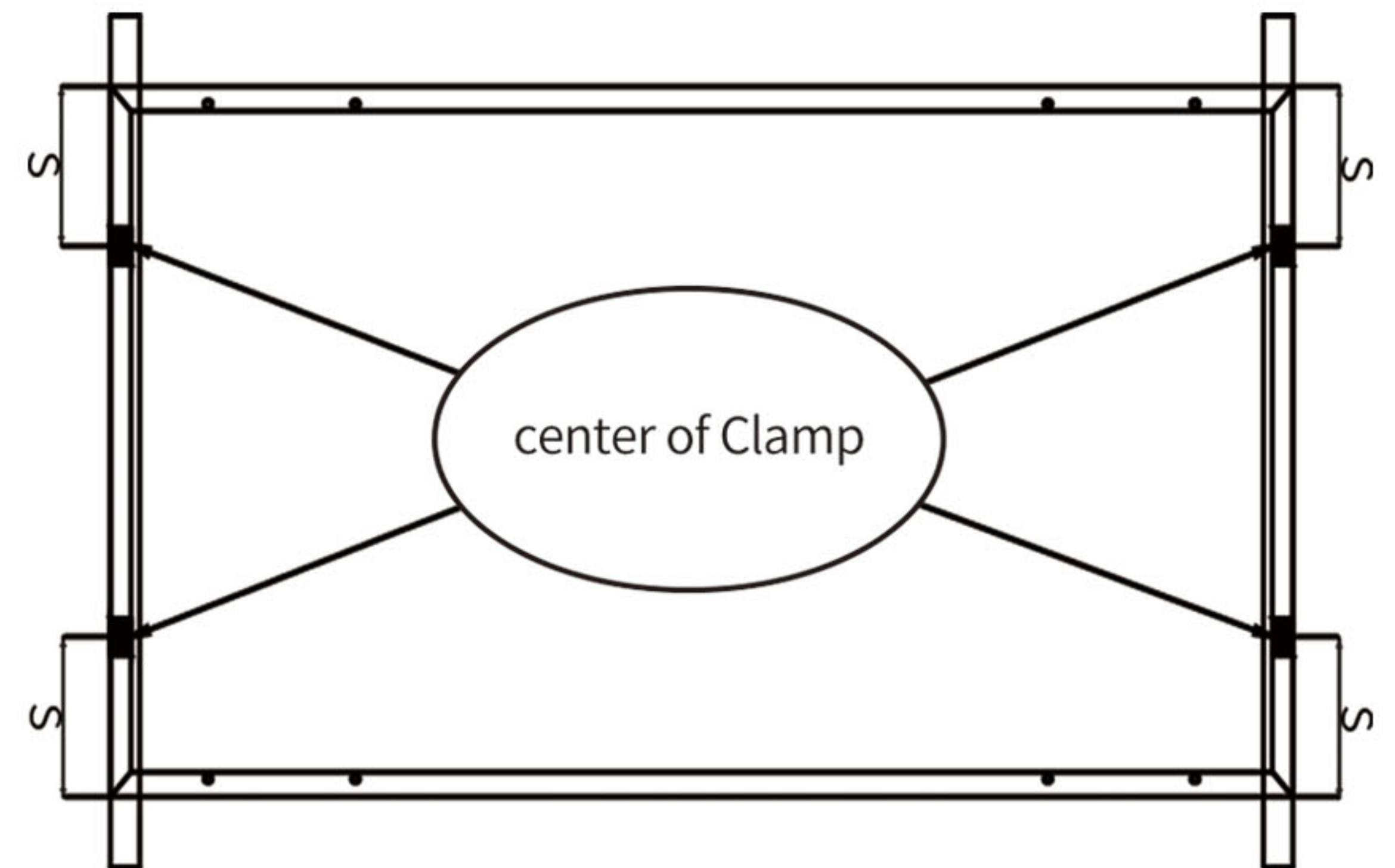
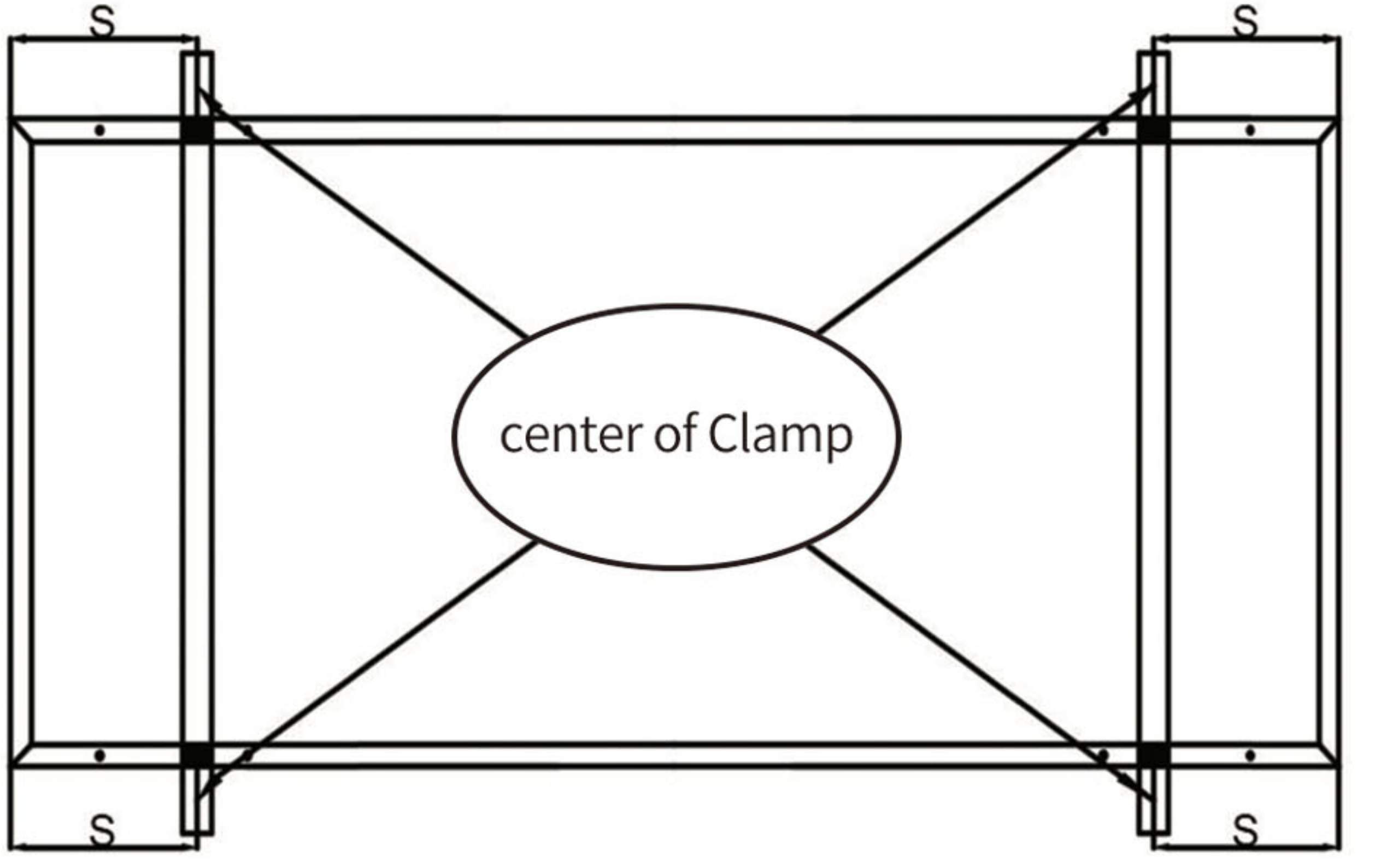
Installation	Mounting System	Clamping System	
	Maximum Load: Uplift load ≤ 2400 Pa Downforce load ≤ 5400 Pa	Maximum Load: Uplift load ≤ 1600 Pa Downforce load ≤ 2000 Pa	Maximum Load: Uplift load ≤ 2400 Pa Downforce load ≤ 5400 Pa
	Use standard mounting holes and reinforce mounting holes	Use four clamps 0mm<S<200mm ■ Permissible Clamp Range	Use four clamps 390mm<S<490mm ■ Permissible Clamp Range
	 <p style="text-align: center;">standard mounting holes</p> <p style="text-align: center;">Reinforce mounting holes</p>	 <p style="text-align: center;">center of Clamp</p>	 <p style="text-align: center;">center of Clamp</p>
	The guide rail should be installed perpendicular to the long side of the frame	The guide rail should be installed perpendicular to the long side of the frame	The guide rail should be installed perpendicular to the long side of the frame

UG Type module (166mm)	
Type	PSXXM5GFH-20/UH; PSXXM5GF-20/UH; PSXXM5GFH-20/USH
Size (mm)	1762mm × 1039mm × 30/35mm; 1756mm × 1039mm × 30/35mm; 1755mm × 1038mm × 30/35mm

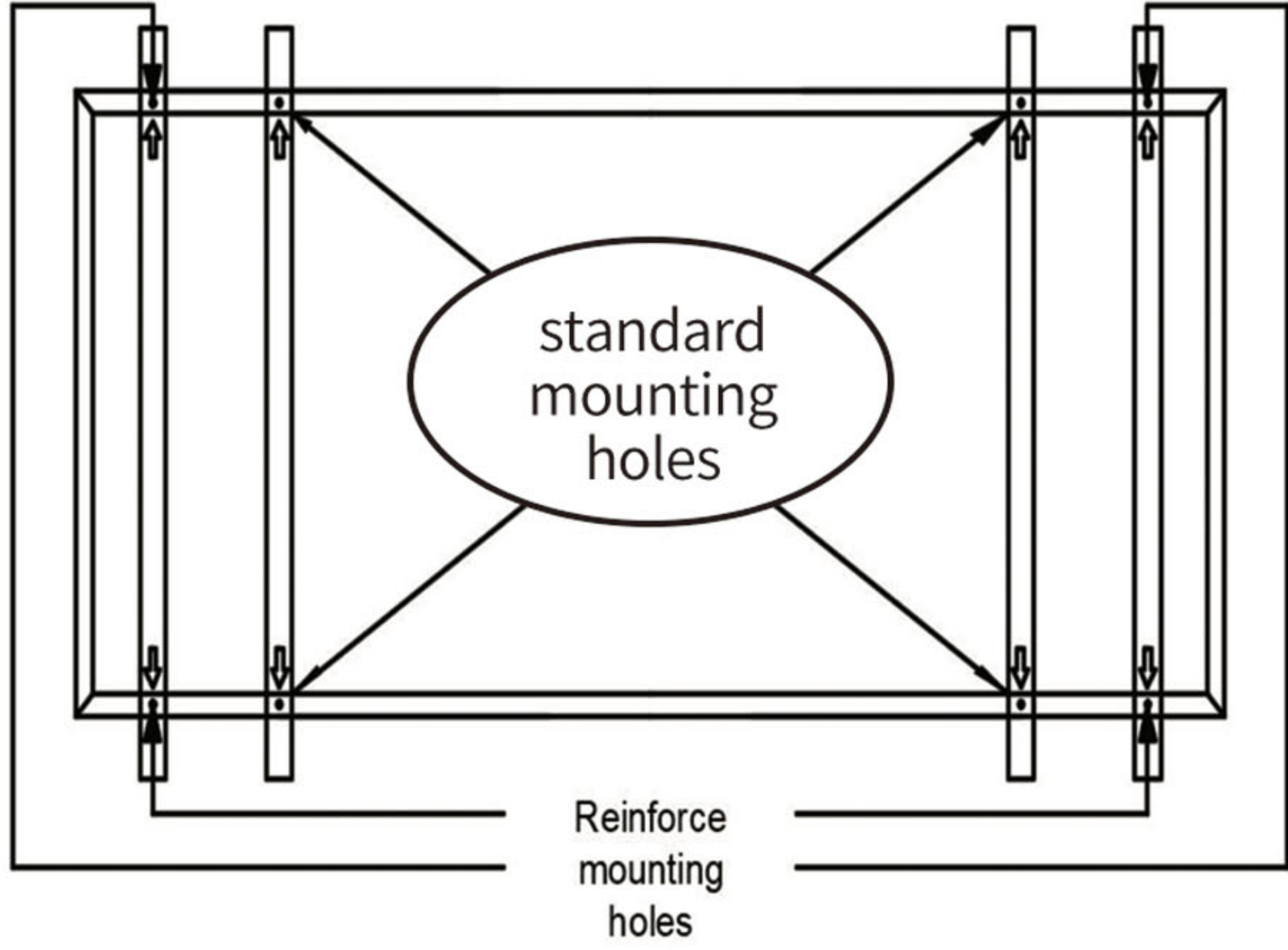
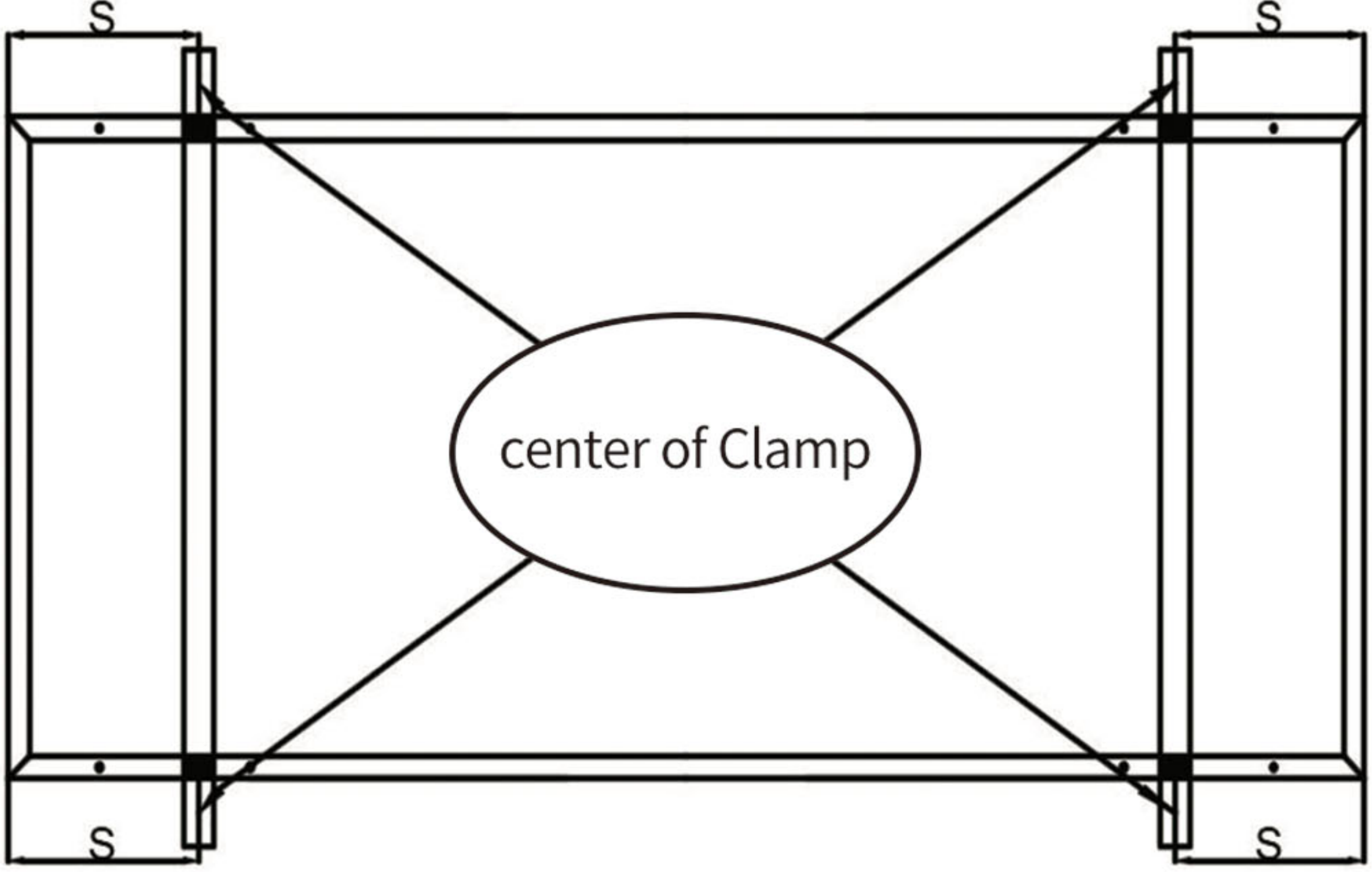
Installation	<h3>Mounting System</h3>	<h3>Clamping System</h3>
	Maximum Load: Uplift load \leq 2400 Pa Downforce load \leq 5400 Pa	Maximum Load: Uplift load \leq 2400 Pa Downforce load \leq 5400 Pa
	Use standard mounting holes and reinforce mounting holes	Use four clamps 390 mm $<$ S $<$ 490 mm ■ Permissible Clamp Range
		
	The guide rail should be installed perpendicular to the long side of the frame	The guide rail should be installed perpendicular to the long side of the frame

U Type module (182mm)	
Type	PSXXM6H-20/UH; PSXXM6-20/UH
Size (mm)	1909mm × 1134mm × 30/35mm; 1903mm × 1134mm × 30/35mm

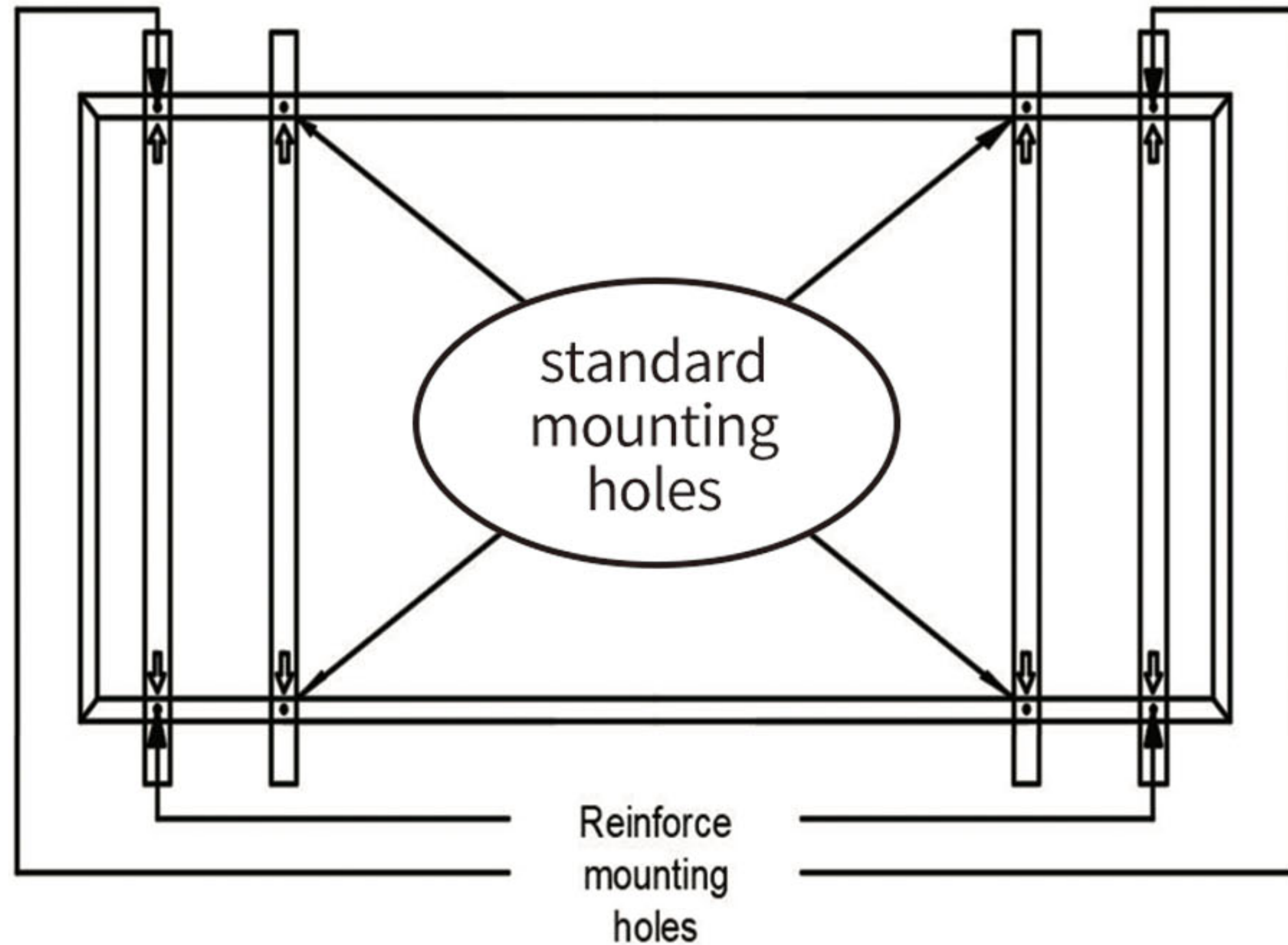
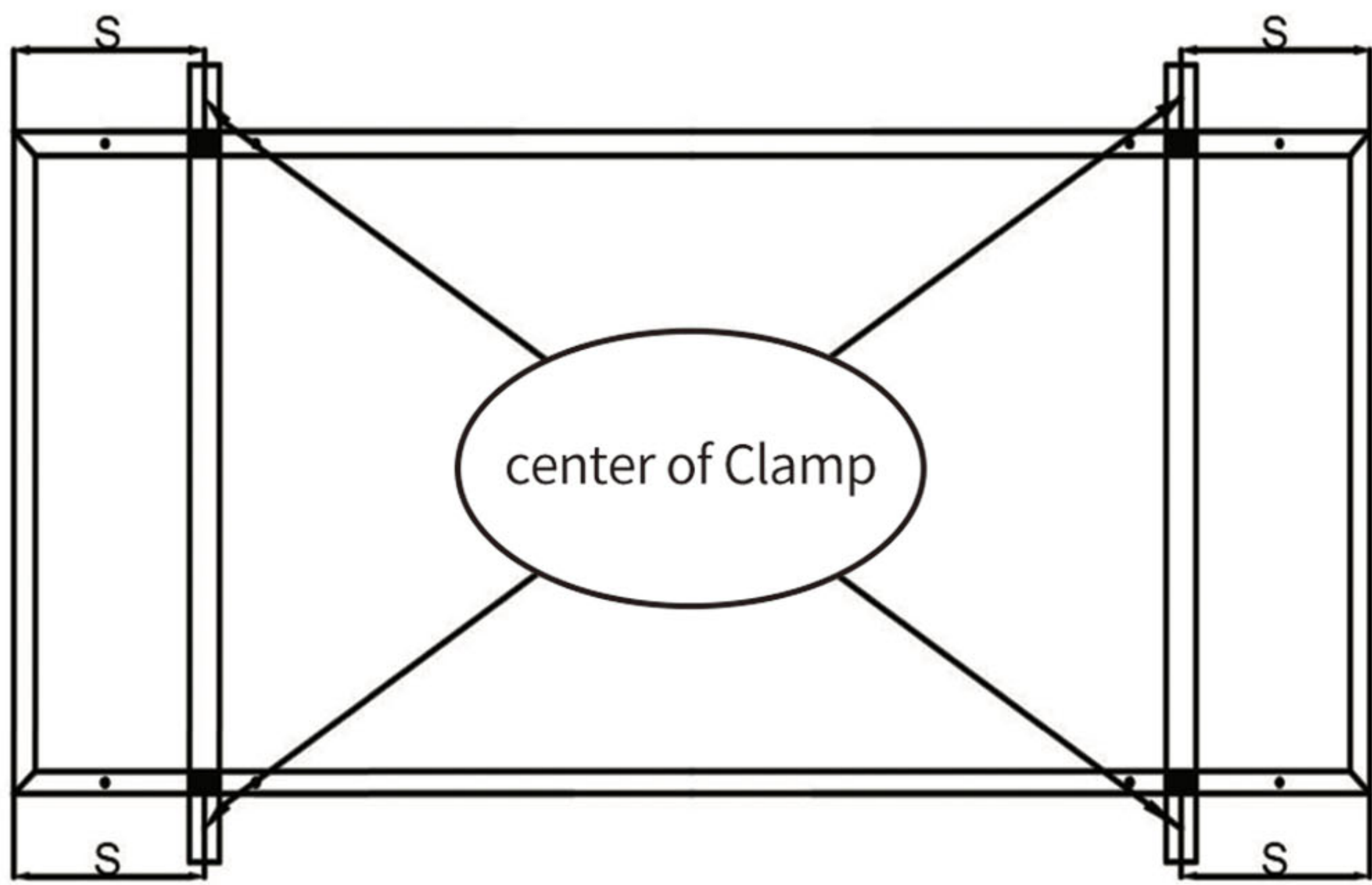
Installation	Mounting System	Clamping System
	Maximum Load: Uplift load \leq 2400 Pa Downforce load \leq 5400 Pa	Maximum Load: Uplift load \leq 2400 Pa Downforce load \leq 5400 Pa
	Use standard mounting holes and reinforce mounting holes	Use four clamps $420\text{mm} < S < 520\text{mm}$ ■ Permissible Clamp Range
		
	The guide rail should be installed perpendicular to the long side of the frame	The guide rail should be installed perpendicular to the long side of the frame

UG Type module (210mm)	
Type	PSXXM13GFH-20/USH; PSXXM13GFH-20/UH
Size (mm)	2172mm × 1303mm × 30/33/35mm

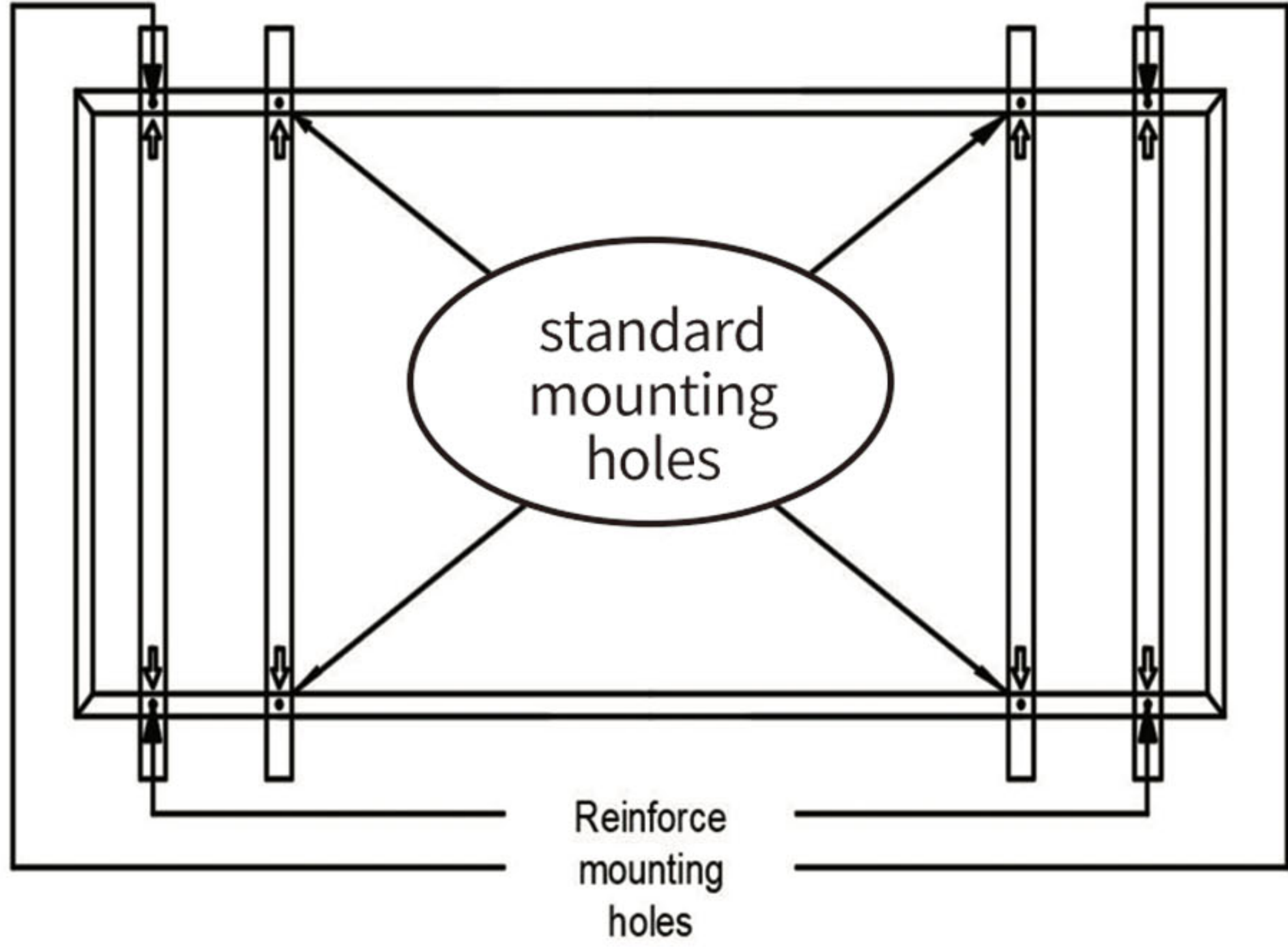
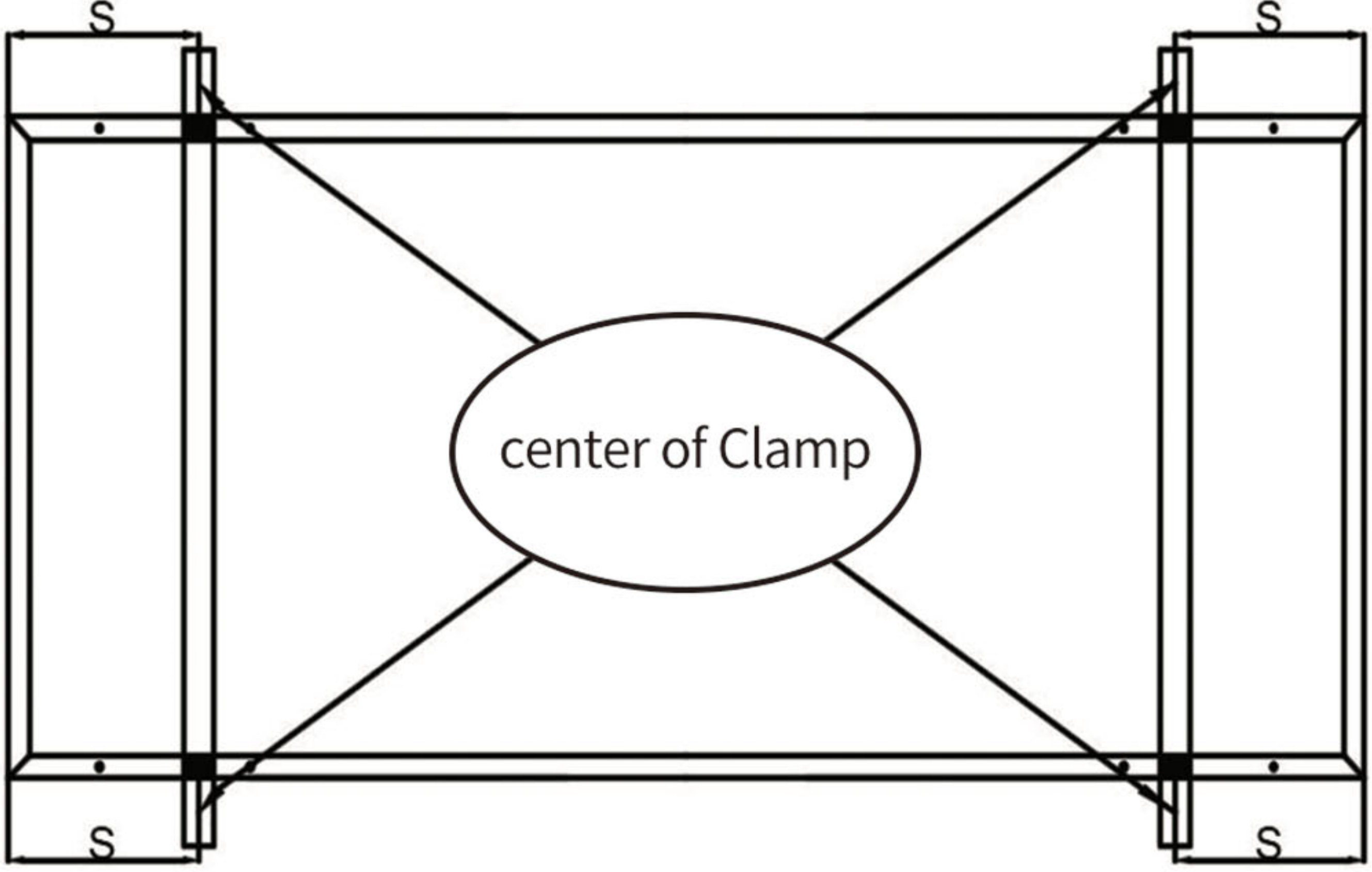
Installation	<h3>Mounting System</h3>	<h3>Clamping System</h3>
	Maximum Load: Uplift load \leq 2400 Pa Downforce load \leq 5400 Pa	Maximum Load: Uplift load \leq 2400 Pa Downforce load \leq 5400 Pa
	Use standard mounting holes and reinforce mounting holes	Use four clamps $360\text{ mm} < S < 430\text{ mm}$ ■ Permissible Clamp Range
		
	The guide rail should be installed perpendicular to the long side of the frame	The guide rail should be installed perpendicular to the long side of the frame

W Type module (166mm)	
Type	PSXXM4H-22/WH; PSXXM4-22/WH; PSXXM5H-22/WH; PSXXM5-22/WH
Size (mm)	1925mm × 1040mm × 30/35mm; 1925mm × 1039mm × 30/35mm; 1924mm × 1038mm × 30/35mm

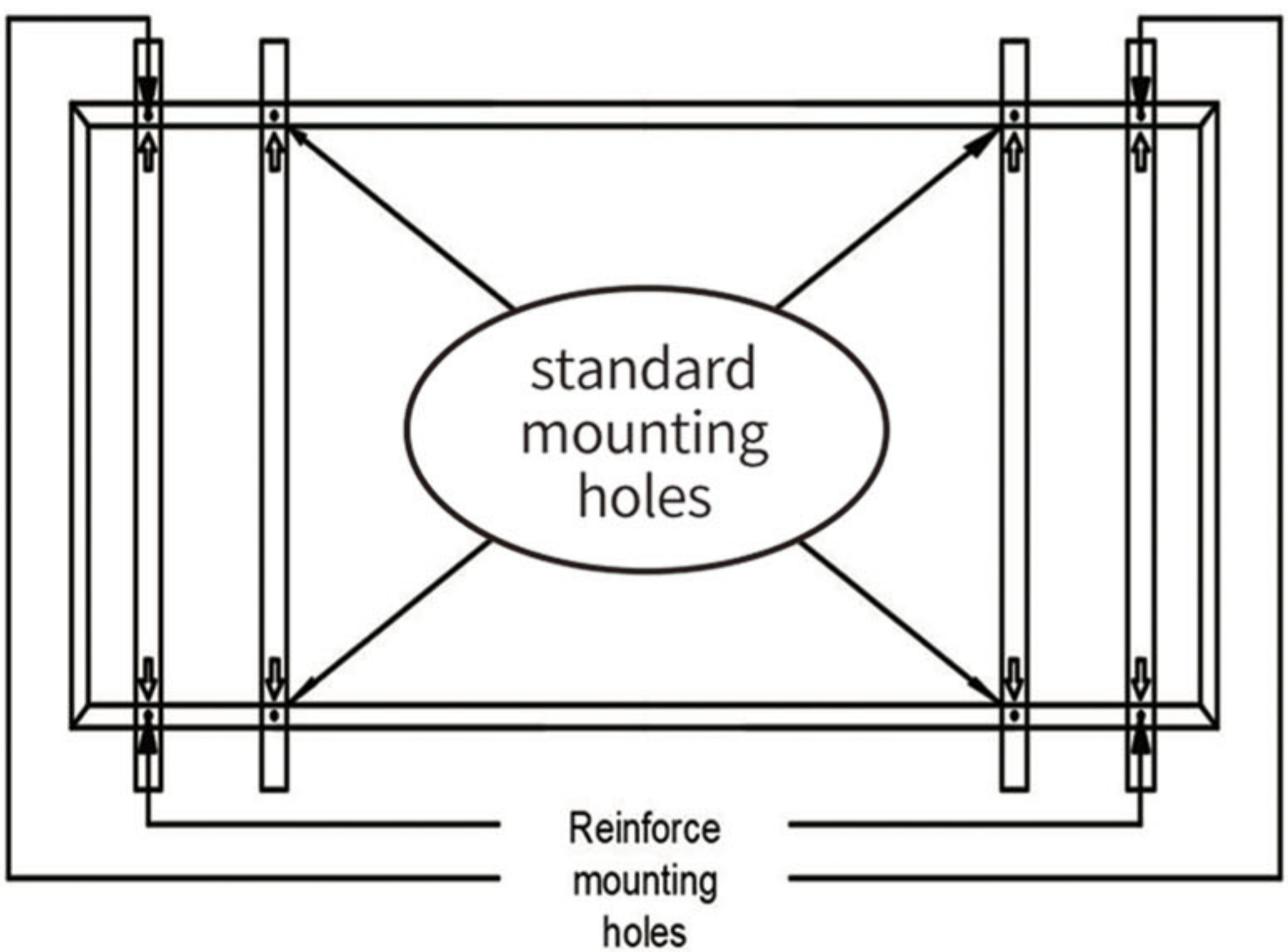
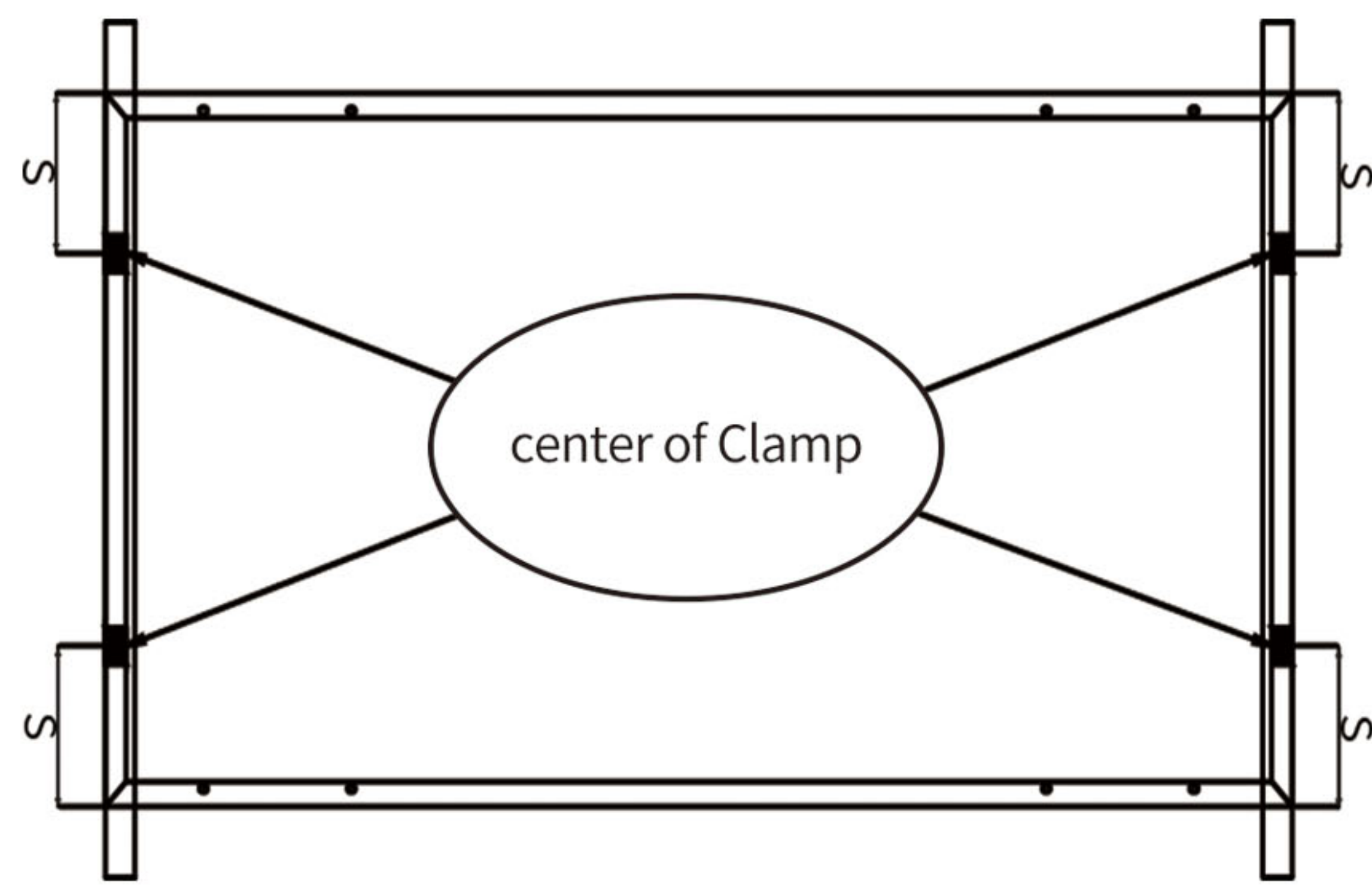
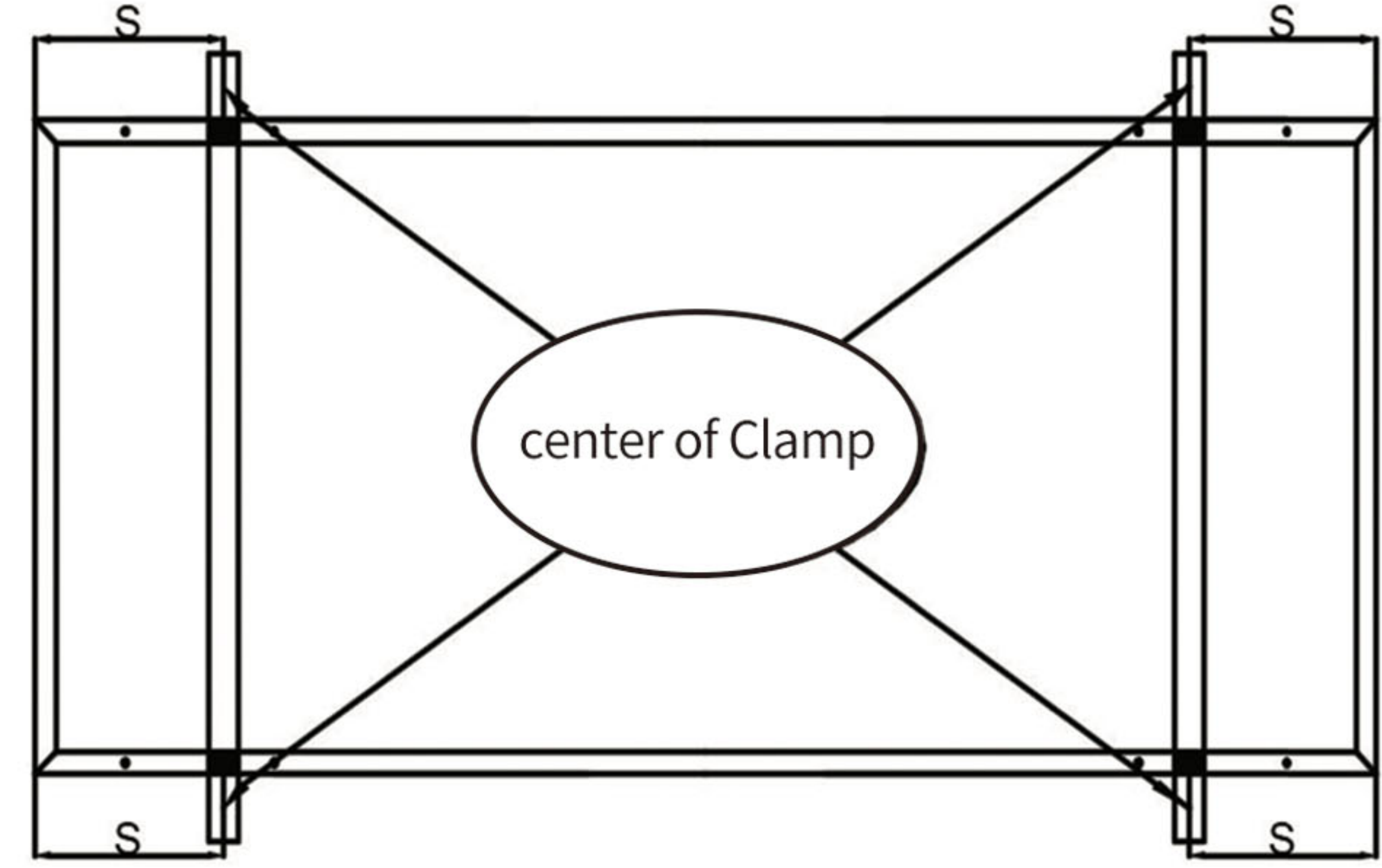
Installation	Mounting System	Clamping System	
	Maximum Load: Uplift load \leq 2400 Pa Downforce load \leq 5400 Pa	Maximum Load: Uplift load \leq 1600 Pa Downforce load \leq 2000 Pa	Maximum Load: Uplift load \leq 2400 Pa Downforce load \leq 5400 Pa
	Use standard mounting holes and reinforce mounting holes	Use four clamps $0\text{mm} < S < 200\text{mm}$ ■ Permissible Clamp Range	Use four clamps $430\text{mm} < S < 530\text{mm}$ ■ Permissible Clamp Range
	 <p style="text-align: center;">standard mounting holes</p> <p style="text-align: center;">Reinforce mounting holes</p>	 <p style="text-align: center;">center of Clamp</p>	 <p style="text-align: center;">center of Clamp</p>
	The guide rail should be installed perpendicular to the long side of the frame	The guide rail should be installed perpendicular to the long side of the frame	The guide rail should be installed perpendicular to the long side of the frame

WG Type module (166mm)	
Type	PSXXM5GFH-22/WSH
Size (mm)	1940mm × 1048mm × 30/35mm

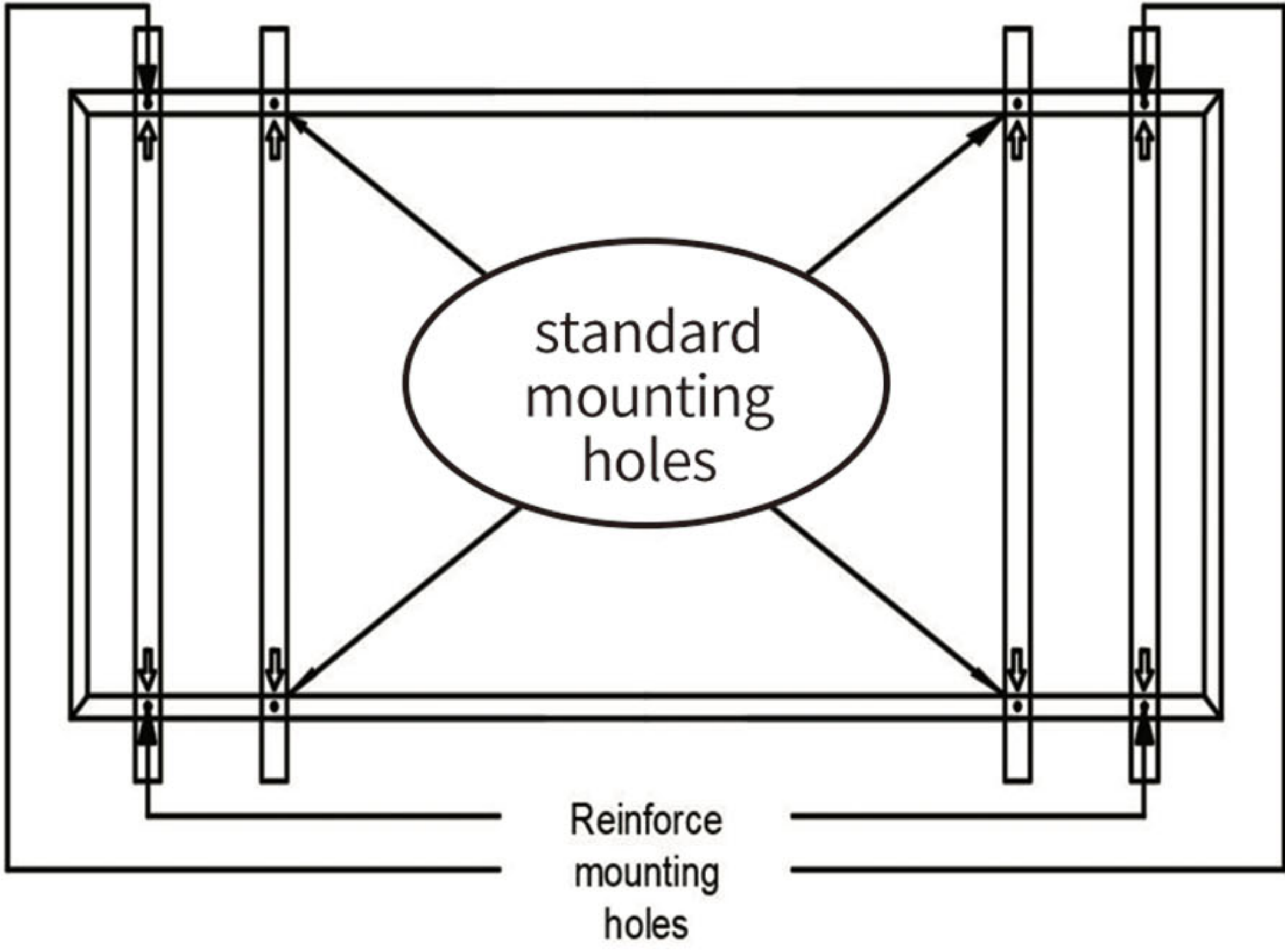
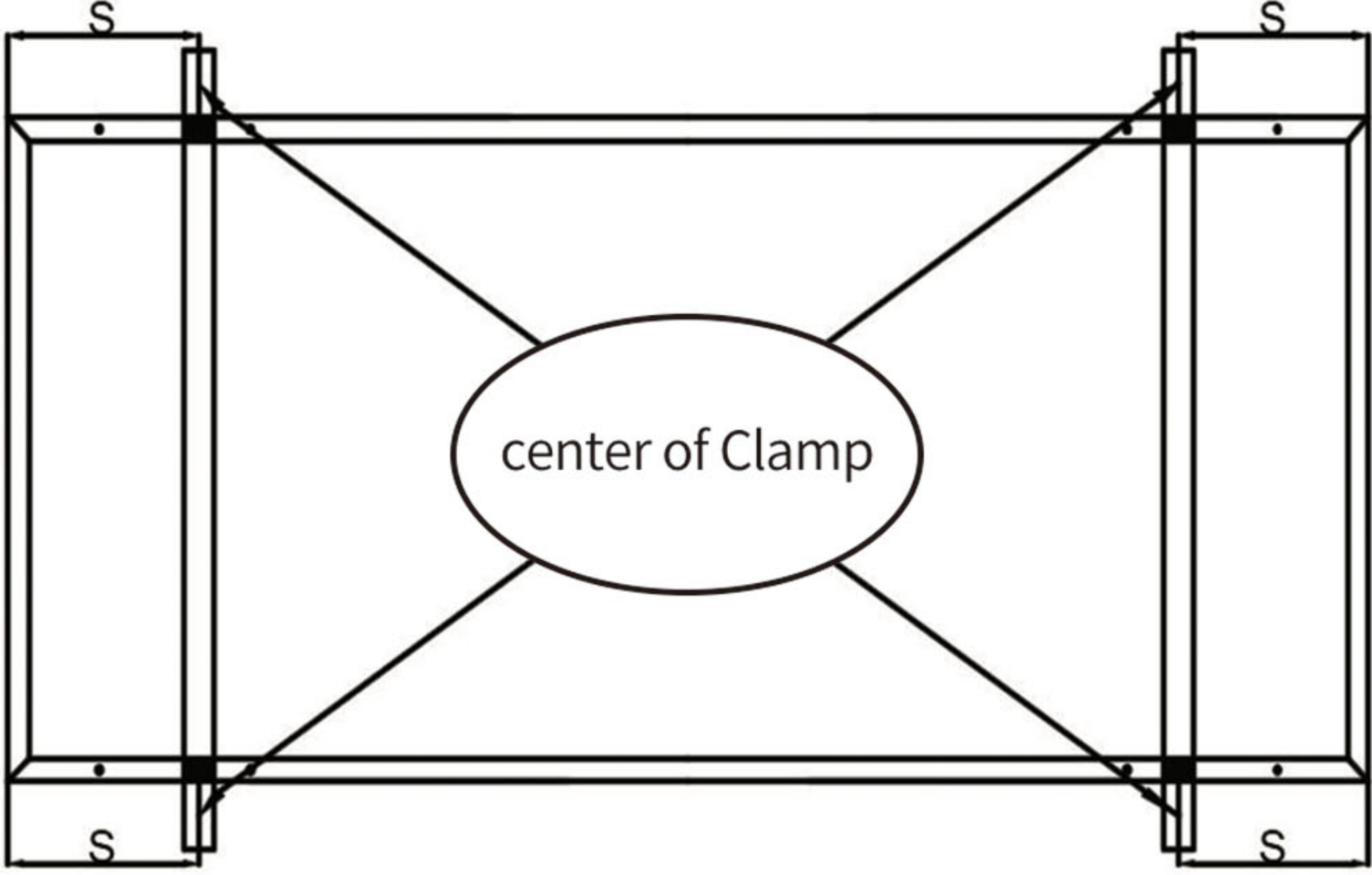
Installation	<h3>Mounting System</h3>	<h3>Clamping System</h3>
	Maximum Load: Uplift load \leq 2400 Pa Downforce load \leq 5400 Pa	Maximum Load: Uplift load \leq 2400 Pa Downforce load \leq 5400 Pa
	Use standard mounting holes and reinforce mounting holes	Use four clamps 435 mm < S < 535 mm ■ Permissible Clamp Range
		
	The guide rail should be installed perpendicular to the long side of the frame	The guide rail should be installed perpendicular to the long side of the frame

W Type module (182mm)	
Type	PSXXM6-22/WH; PSXXM6H-22/WH
Size (mm)	2094mm × 1134mm × 30/35mm; 2073mm × 1134mm × 30/35mm

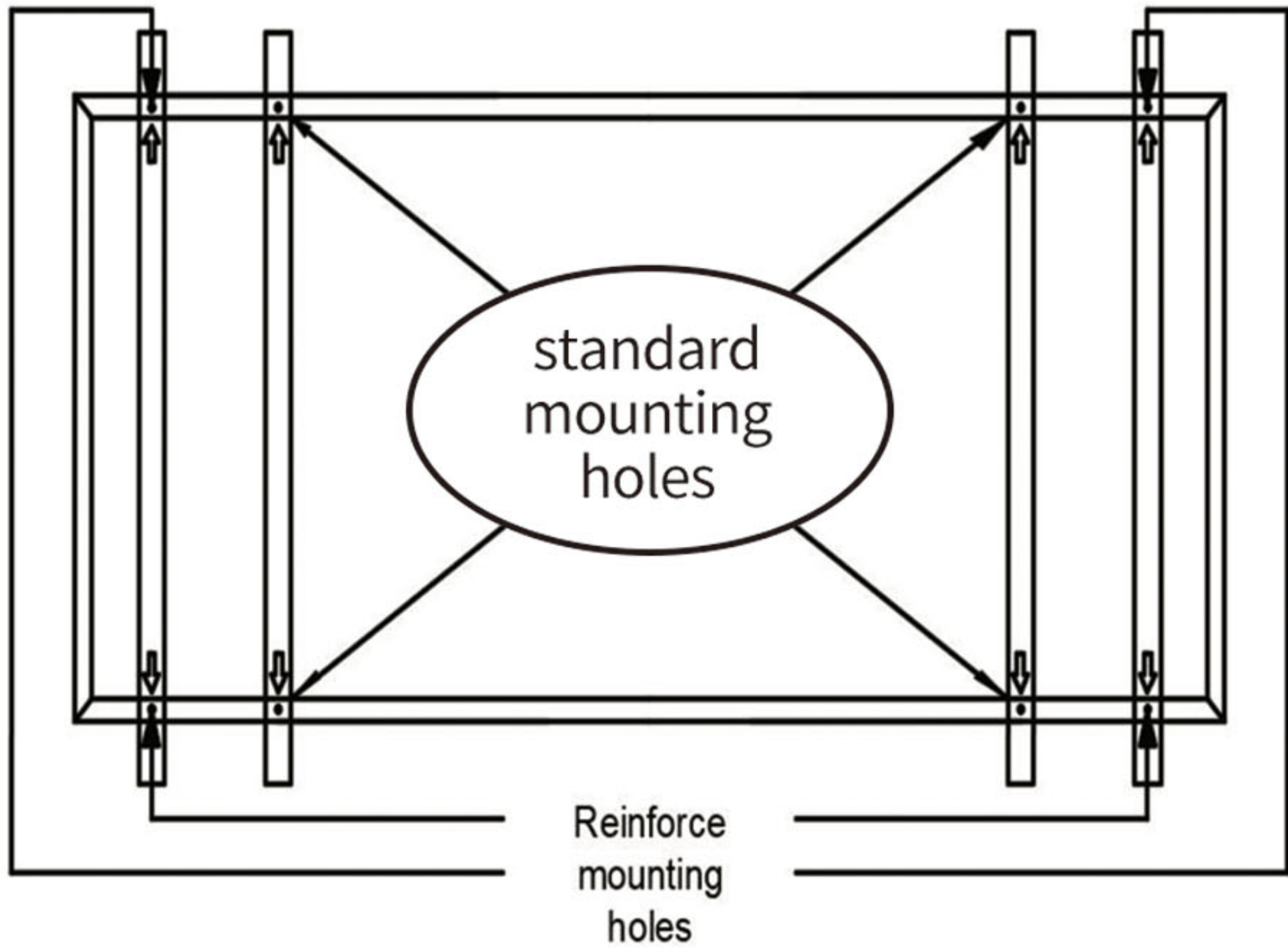
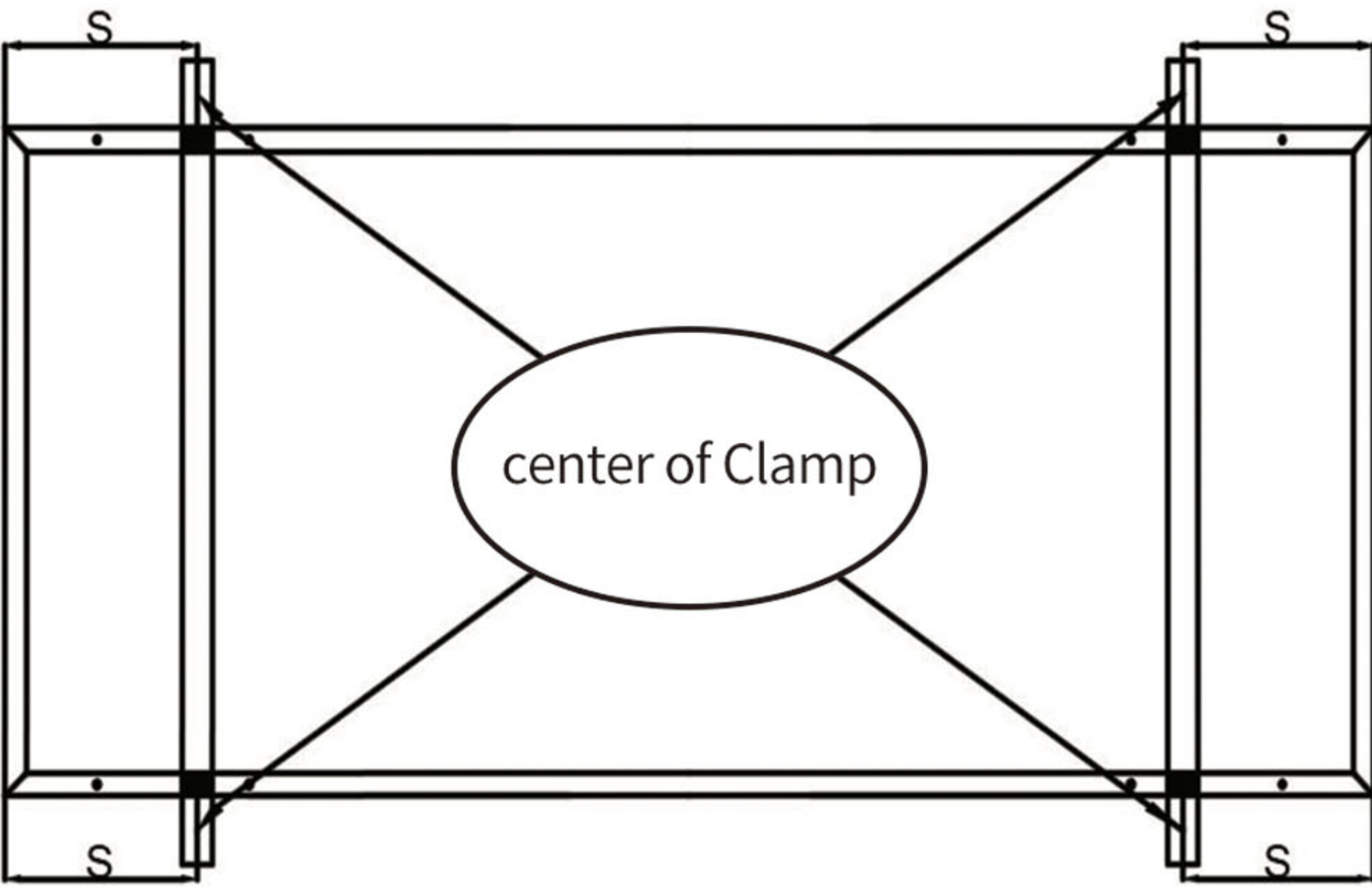
Installation	Mounting System	Clamping System
	Maximum Load: Uplift load \leq 2400 Pa Downforce load \leq 5400 Pa	Maximum Load: Uplift load \leq 2400 Pa Downforce load \leq 5400 Pa
	Use standard mounting holes and reinforce mounting holes	Use four clamps $470\text{mm} < S < 570\text{mm}$ ■ Permissible Clamp Range
		
	The guide rail should be installed perpendicular to the long side of the frame	The guide rail should be installed perpendicular to the long side of the frame

WG Type module (210mm)	
Type	PSXXM13GFH-22/WSH; PSXXM13GFH-22/WH
Size (mm)	2384mm × 1303mm × 30/33/35mm

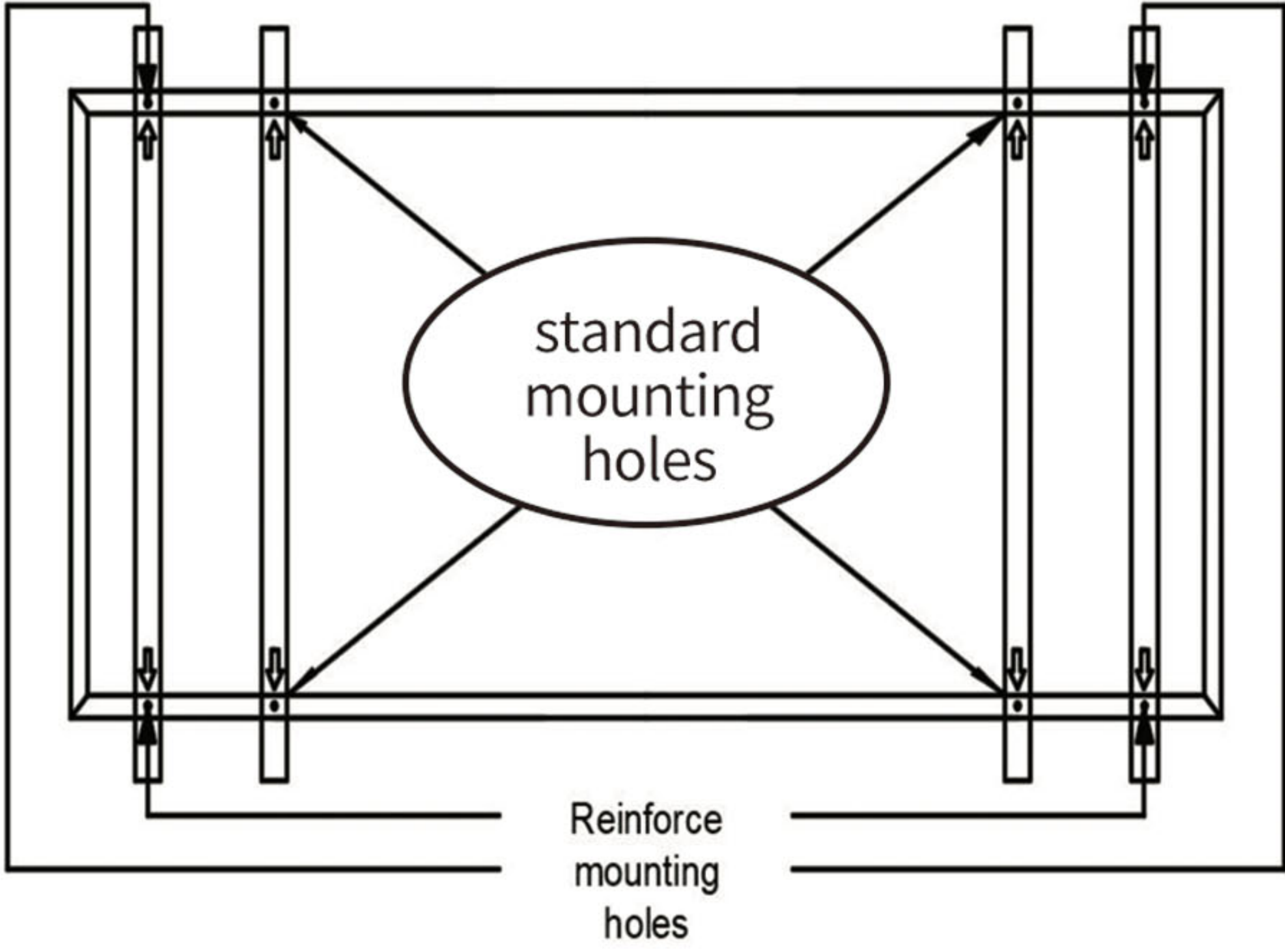
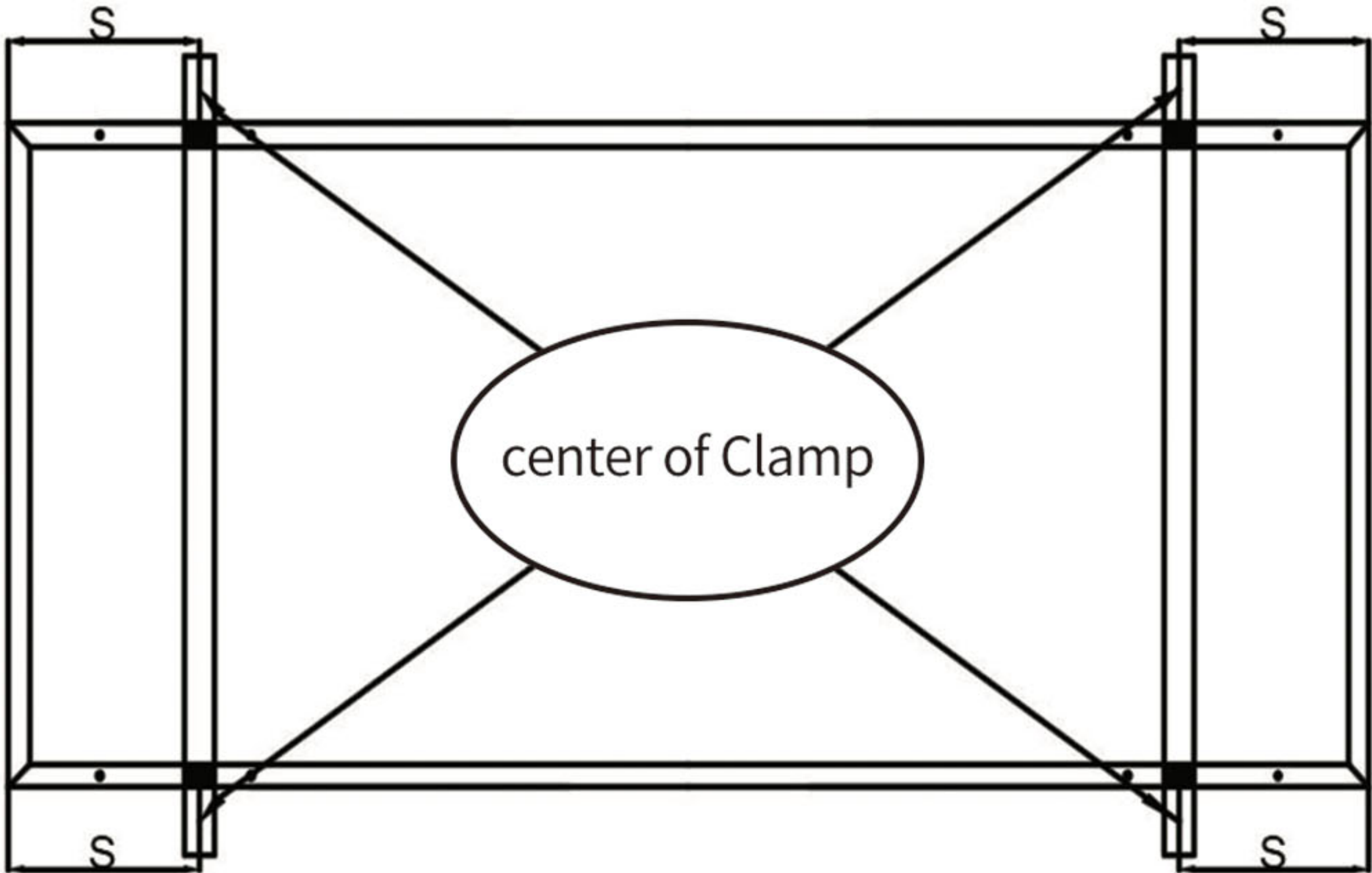
Installation	<h3>Mounting System</h3>	<h3>Clamping System</h3>
	Maximum Load: Uplift load \leq 2400 Pa Downforce load \leq 5400 Pa	Maximum Load: Uplift load \leq 2400 Pa Downforce load \leq 5400 Pa
	Use standard mounting holes and reinforce mounting holes	Use four clamps 440 mm < S < 540mm ■ Permissible Clamp Range
		
	The guide rail should be installed perpendicular to the long side of the frame	The guide rail should be installed perpendicular to the long side of the frame

T Type module (156.75mm, 158.75mm)	
Type	PSXXPH-24/T; PSXXP-24/T; PSXXPH-24/TH; PSXXP-24/TH; PSXXMH-24/T; PSXXM-24/T; PSXXM1H-24/T; PSXXM1-24/T; PSXXMH-24/TH; PSXXM-24/TH; PSXXM1H-24/TH; PSXXM1-24/TH; PSXXMGFH-24/TH; PSXXMGF-24/TH
Size (mm)	2010mm × 1000mm × 40/45mm; 2006mm × 998mm × 30 mm; 2000mm × 992mm × 40/45/50mm ; 1980mm × 1000mm × 40/45mm; 1956mm × 992mm × 40/45/50mm

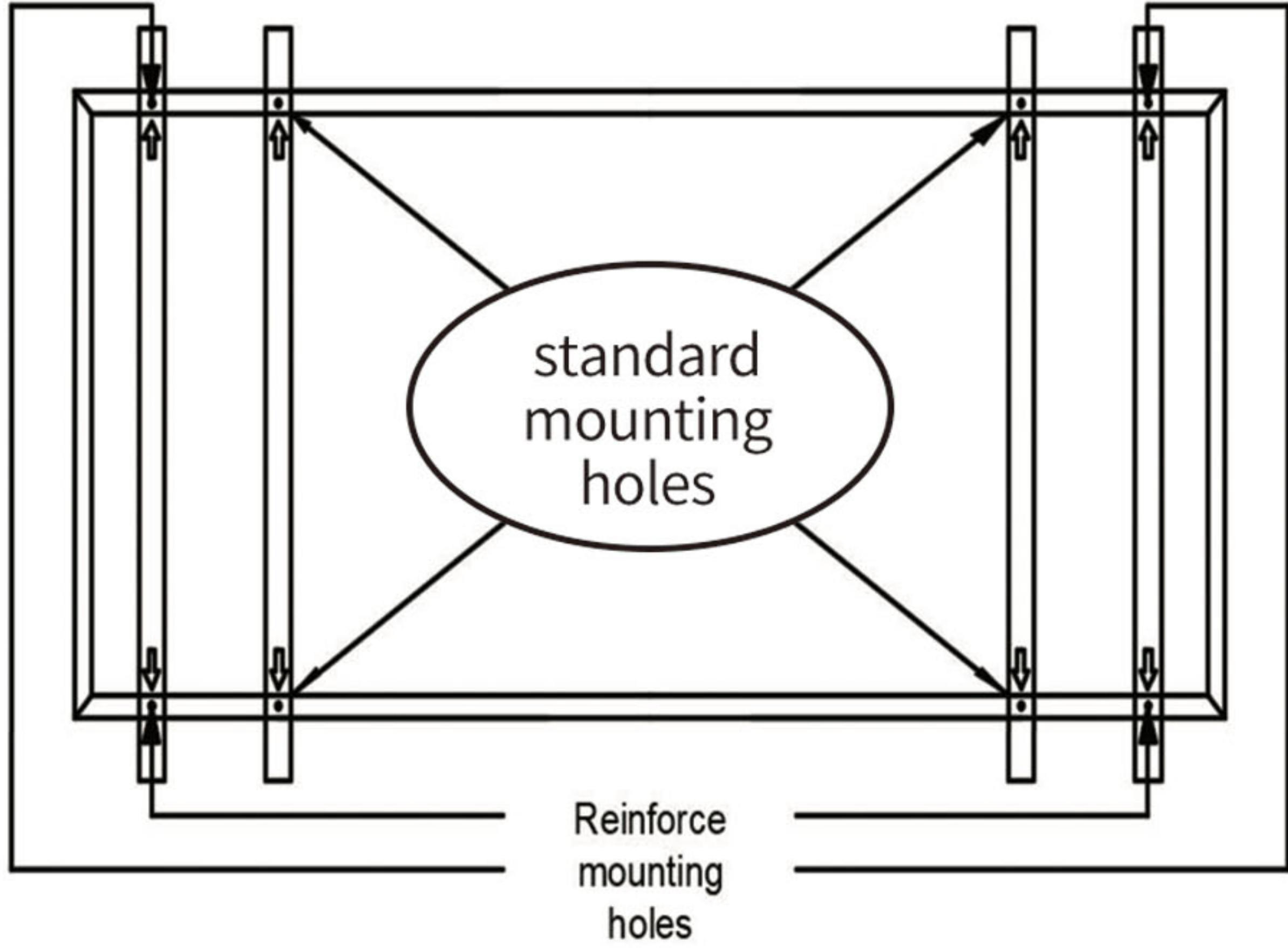
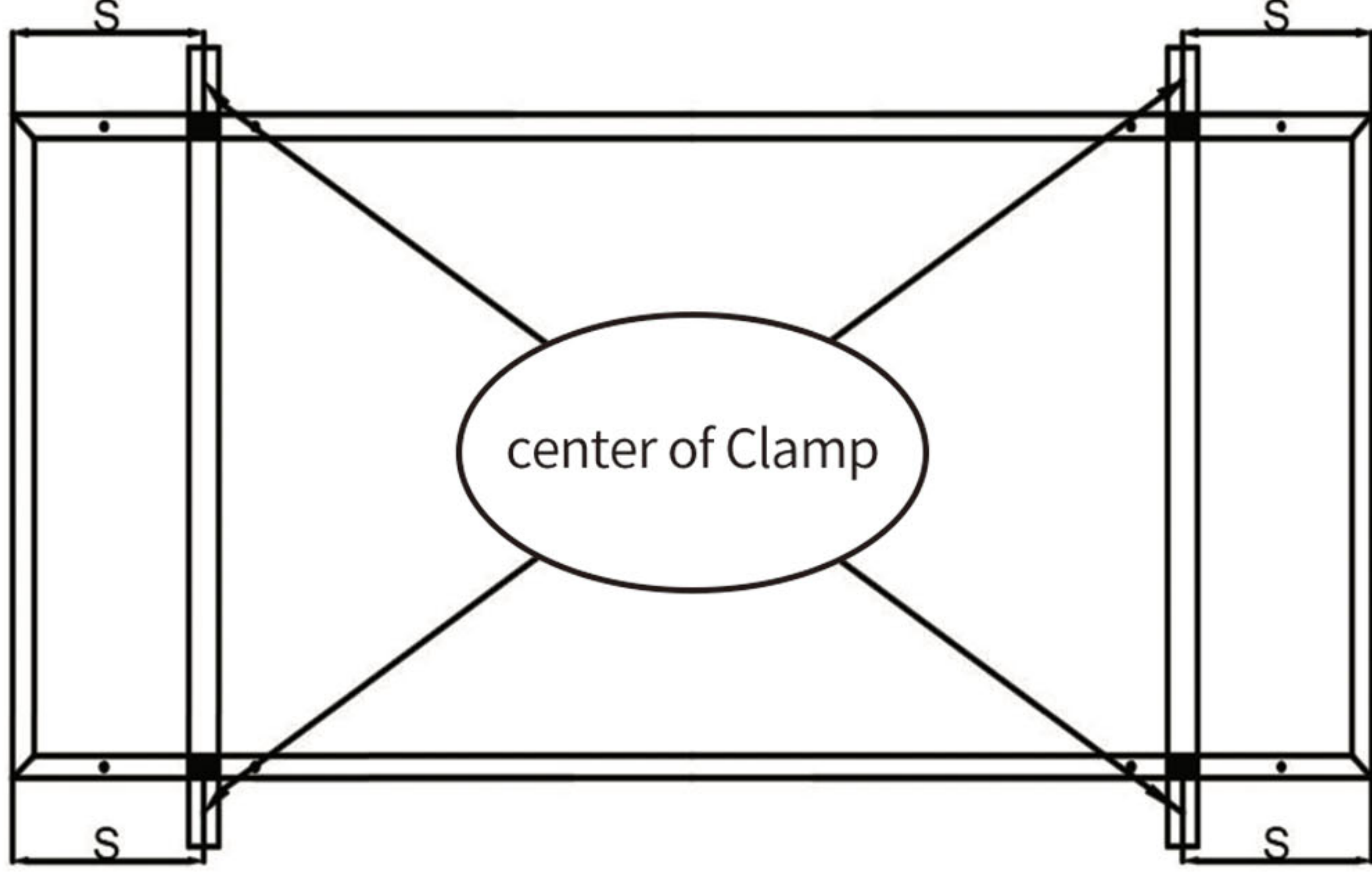
Installation	<h3>Mounting System</h3>	<h3>Clamping System</h3>
	Maximum Load: Uplift load \leq 2400 Pa Downforce load \leq 5400 Pa	Maximum Load: Uplift load \leq 2400 Pa Downforce load \leq 5400 Pa
	Use standard mounting holes and reinforce mounting holes	Use four clamps $300\text{mm} < S < 350\text{mm}$ ■ Permissible Clamp Range
		
	The guide rail should be installed perpendicular to the long side of the frame	The guide rail should be installed perpendicular to the long side of the frame

T Type module (166mm)	
Type	PSXXM4H-24/TH; PSXXM4-24/TH; PSXXM5H-24/TH; PSXXM5-24/TH;
Size (mm)	2115mm × 1052mm × 30/35mm; 2103mm × 1040mm × 30/35mm; 2101mm × 1039mm × 30/35mm; 2095mm × 1039mm × 30/35mm; 2094mm × 1038mm × 30/35mm;

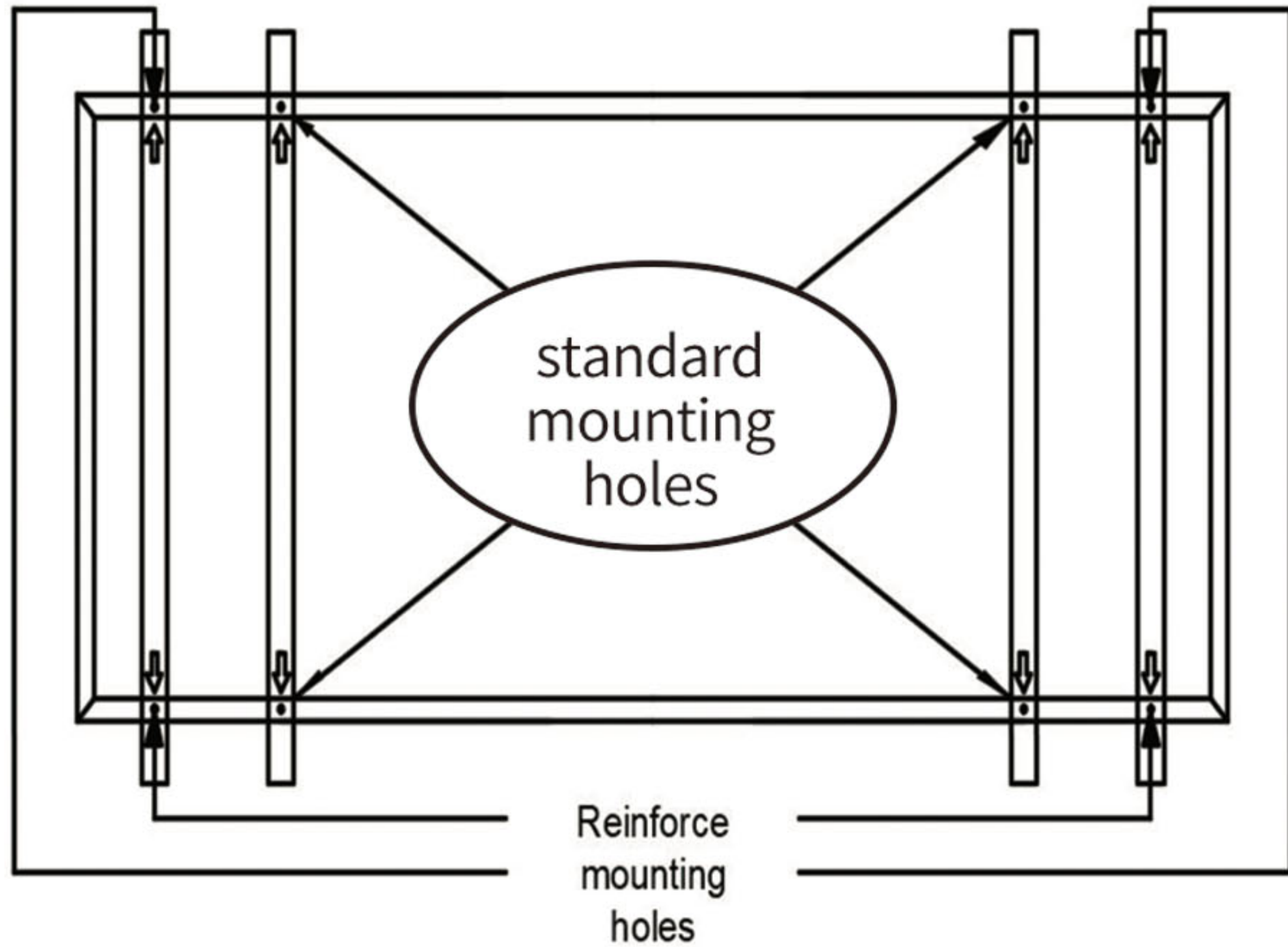
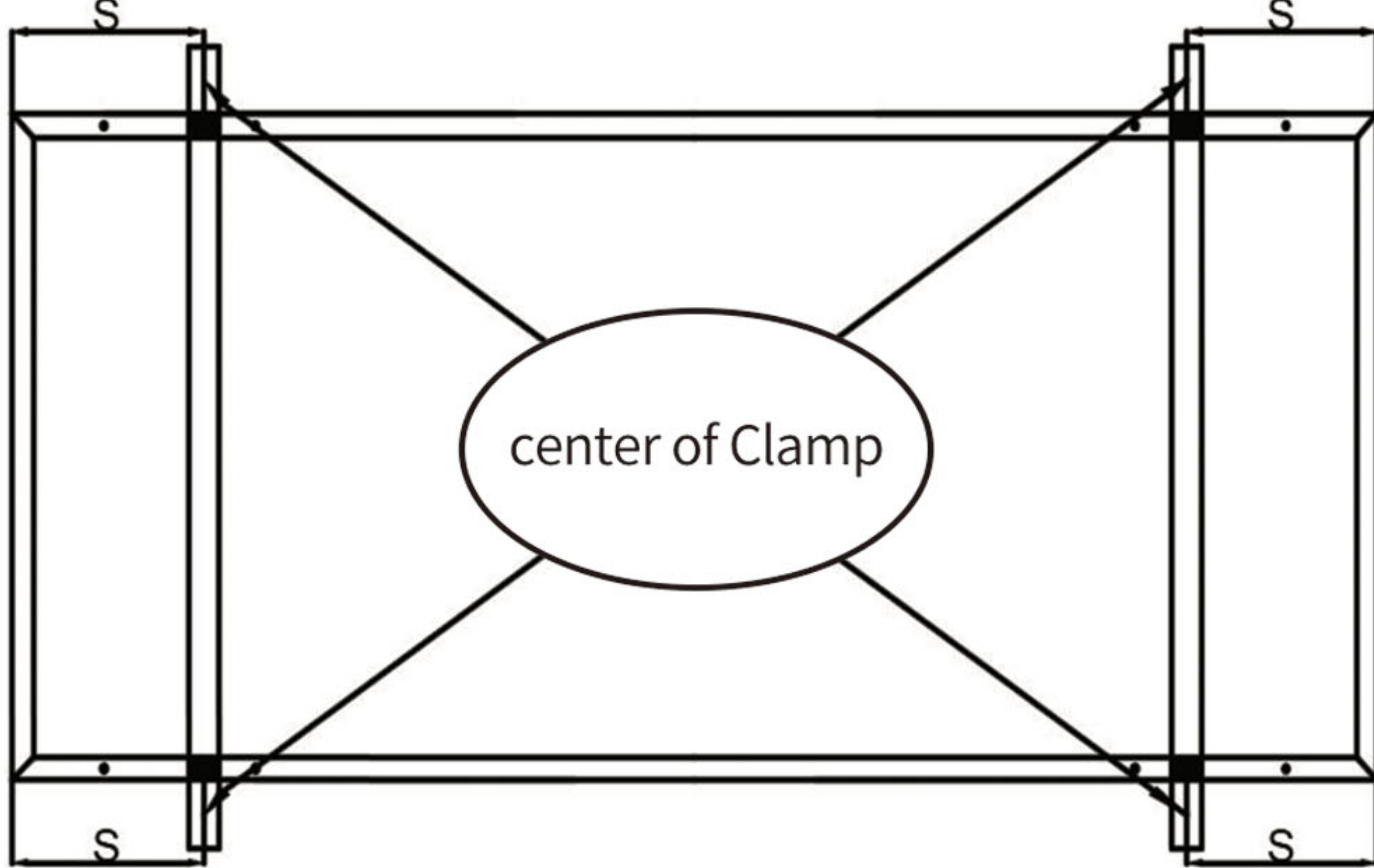
Installation	<h3>Mounting System</h3>	<h3>Clamping System</h3>
	Maximum Load: Uplift load \leq 2400 Pa Downforce load \leq 5400 Pa	Maximum Load: Uplift load \leq 2400 Pa Downforce load \leq 5400 Pa
	Use standard mounting holes and reinforce mounting holes	Use four clamps $475\text{mm} < S < 575\text{mm}$ ■ Permissible Clamp Range
	 <p style="text-align: center;">standard mounting holes</p> <p style="text-align: center;">Reinforce mounting holes</p>	 <p style="text-align: center;">center of Clamp</p>
	The guide rail should be installed perpendicular to the long side of the frame	The guide rail should be installed perpendicular to the long side of the frame

TG Type module (166mm)	
Type	PSXXM5GFH-24/TH; PSXXM5GF-24/TH; PSXXM5GFH-24/TSH
Size (mm)	2132mm × 1048mm × 30mm; 2094mm × 1038mm × 30mm

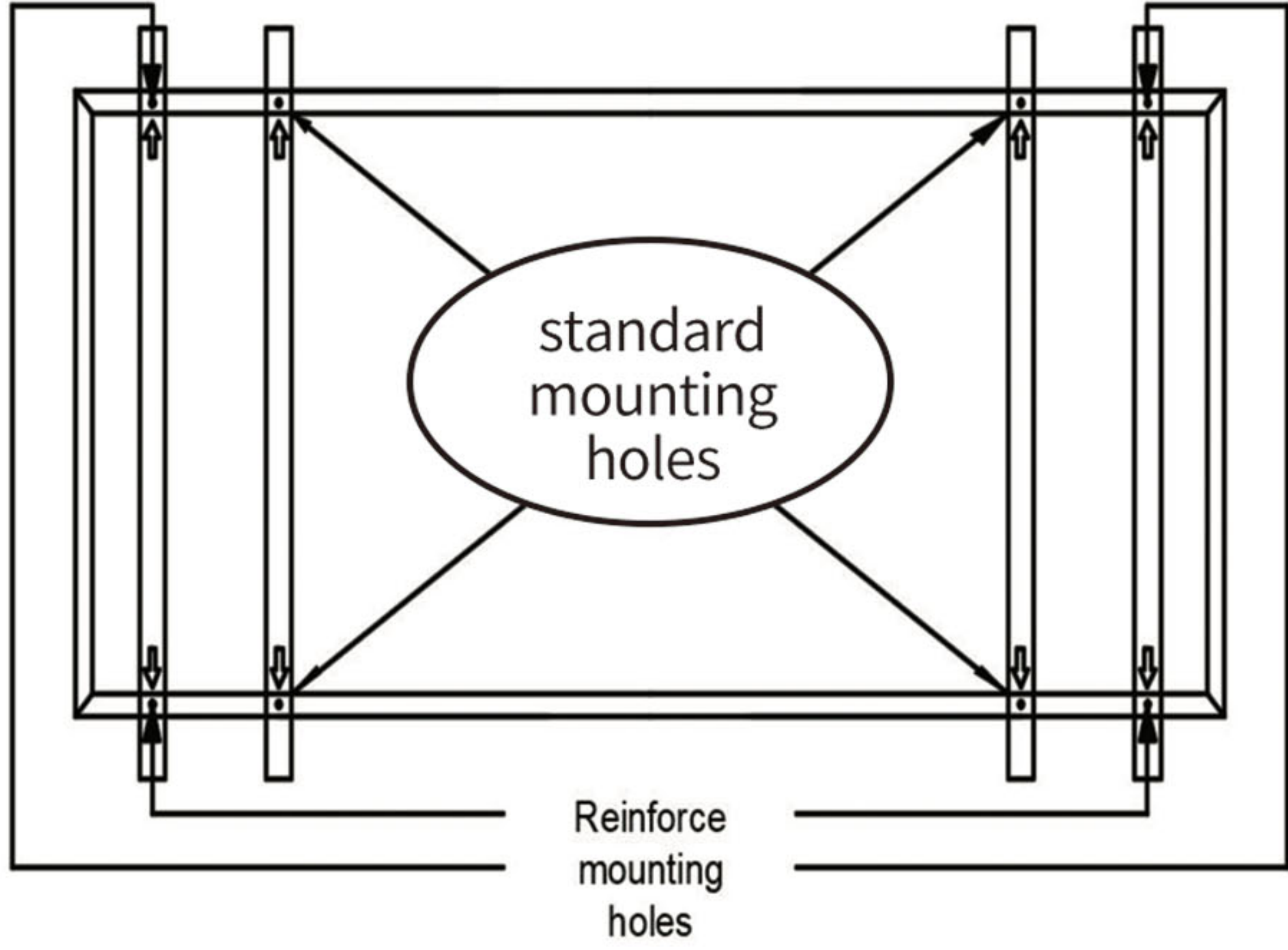
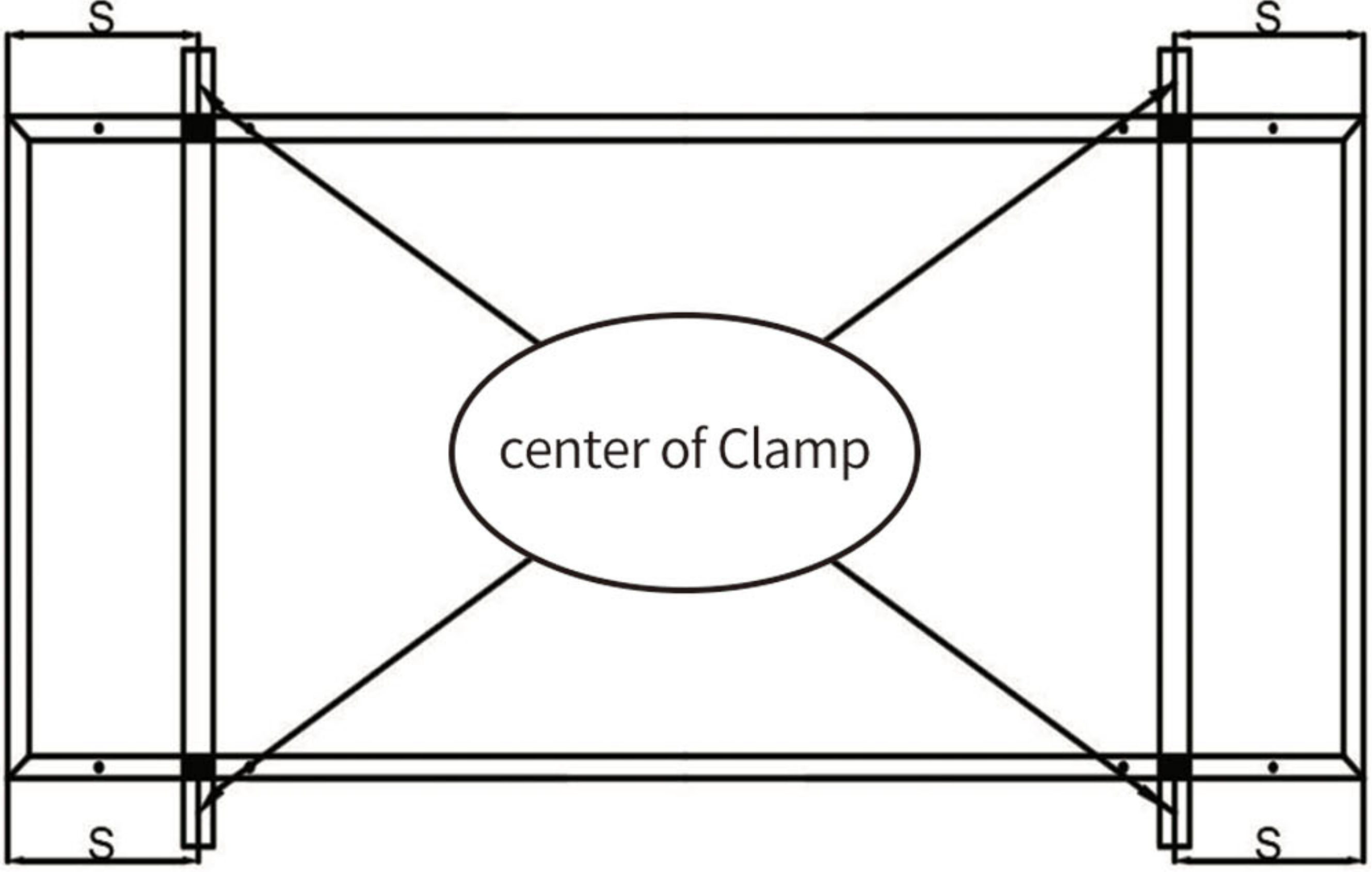
Installation	<h3>Mounting System</h3>	<h3>Clamping System</h3>
	Maximum Load: Uplift load \leq 2400 Pa Downforce load \leq 5400 Pa	Maximum Load: Uplift load \leq 2400 Pa Downforce load \leq 5400 Pa
	Use standard mounting holes and reinforce mounting holes	Use four clamps 475 mm < S < 575mm ■ Permissible Clamp Range
		
	The guide rail should be installed perpendicular to the long side of the frame	The guide rail should be installed perpendicular to the long side of the frame

T Type module (182mm)	
Type	PSXXM6H-24/TH; PSXXM6-24/TH
Size (mm)	2279mm × 1134mm × 35mm; 2278 × 1134 × 35mm; 2274mm × 1134mm × 35mm; 2256mm × 1134mm × 35mm

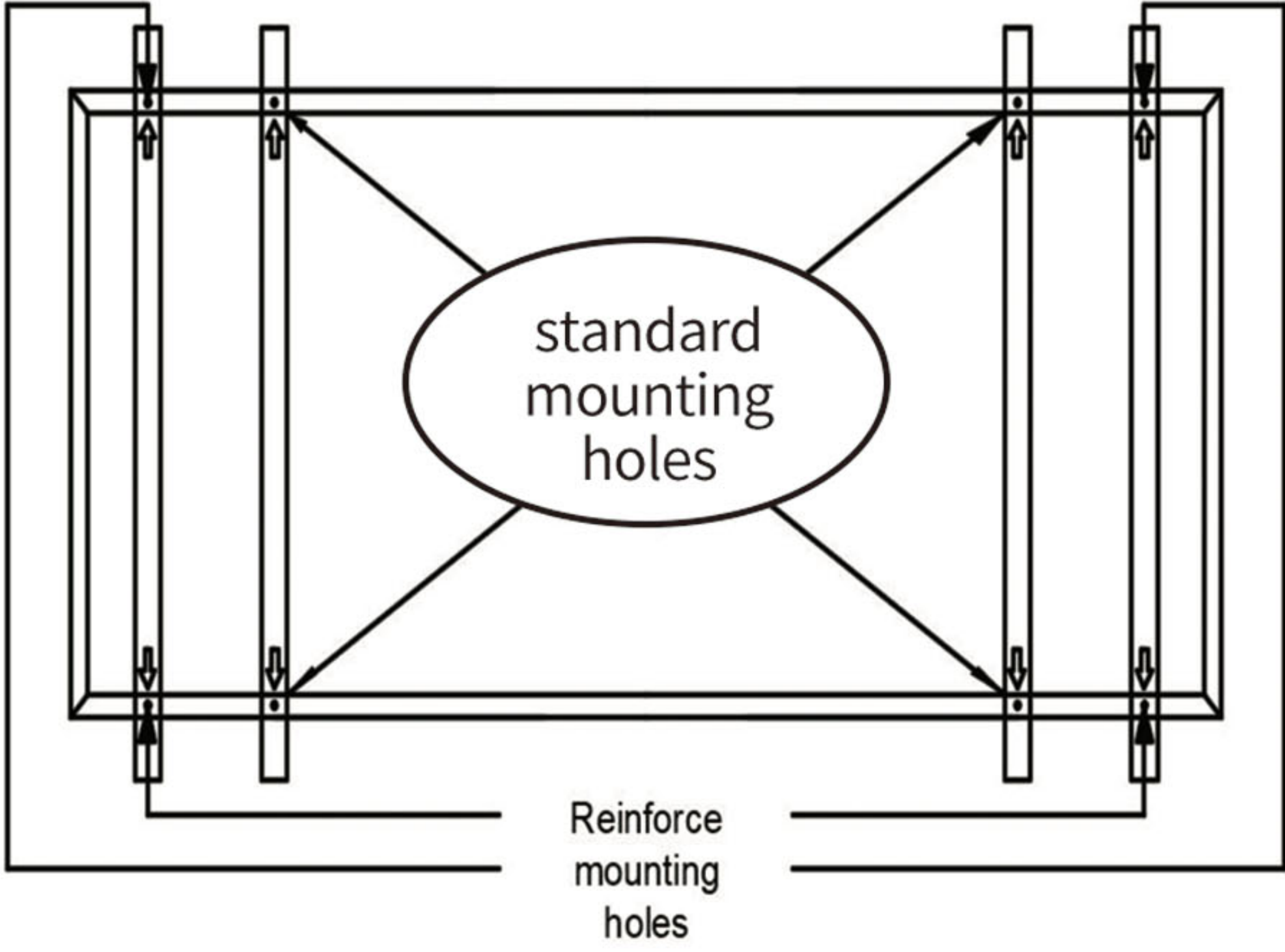
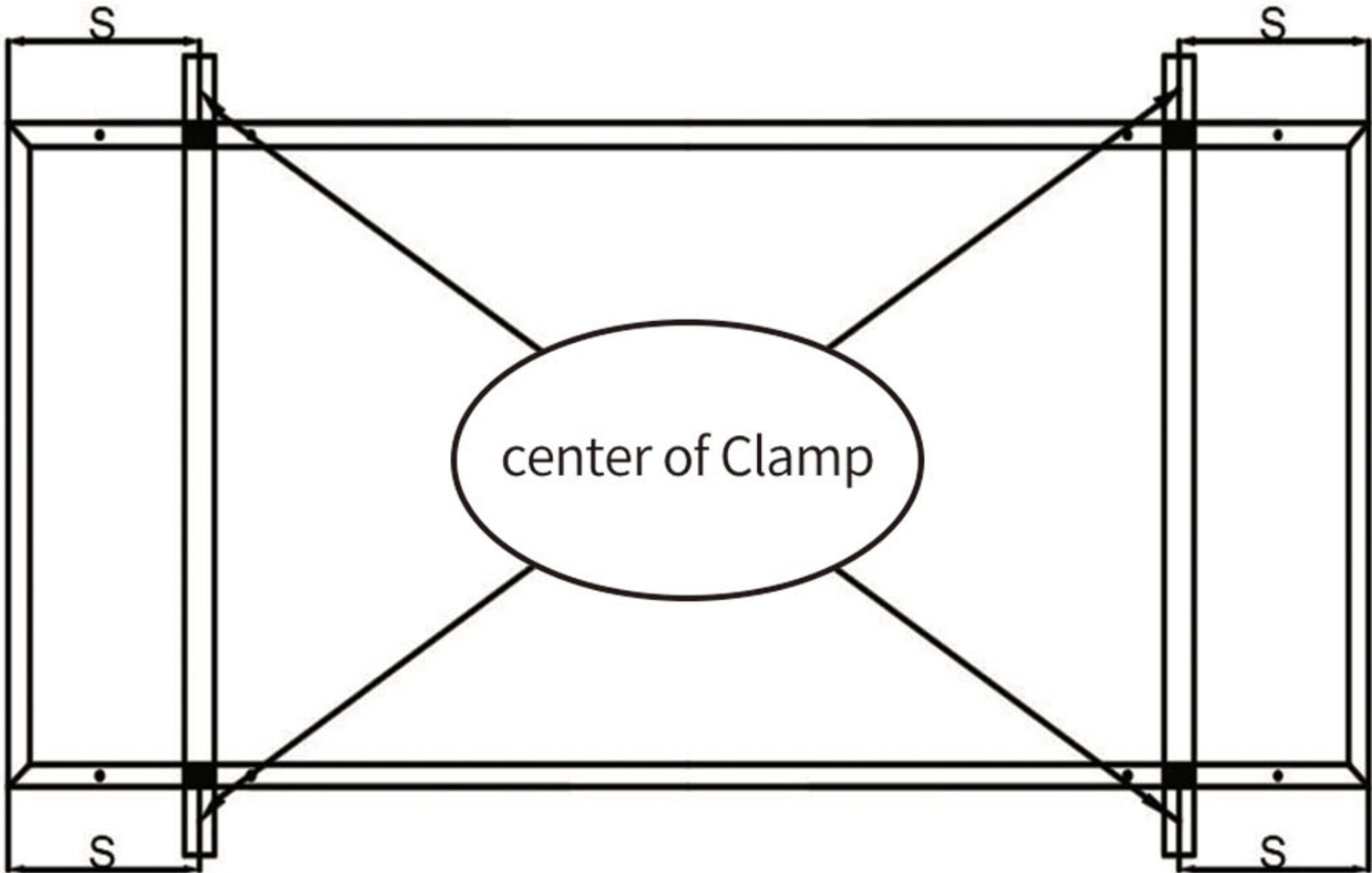
Installation	Mounting System	Clamping System
	Maximum Load: Uplift load \leq 2400 Pa Downforce load \leq 5400 Pa	Maximum Load: Uplift load \leq 2400 Pa Downforce load \leq 5400 Pa
	Use standard mounting holes and reinforce mounting holes	Use four clamps 520 mm < S < 620mm ■ Permissible Clamp Range
		
	The guide rail should be installed perpendicular to the long side of the frame	The guide rail should be installed perpendicular to the long side of the frame

TG Type module (182mm)	
Type	PSXXM7GFH-24/TH; PSXXM7GF-24/TH; PSXXM8GFH-24/TH; PSXXM8GF-24/TH; PSXXM8GF-24/TNH; PSXXM8GFH-24/TNH
Size (mm)	2279mm × 1134mm × 30/35mm; 2278mm × 1134mm × 30/35mm; 2274mm × 1134mm × 30/35mm; 2256mm × 1134mm × 30/35mm

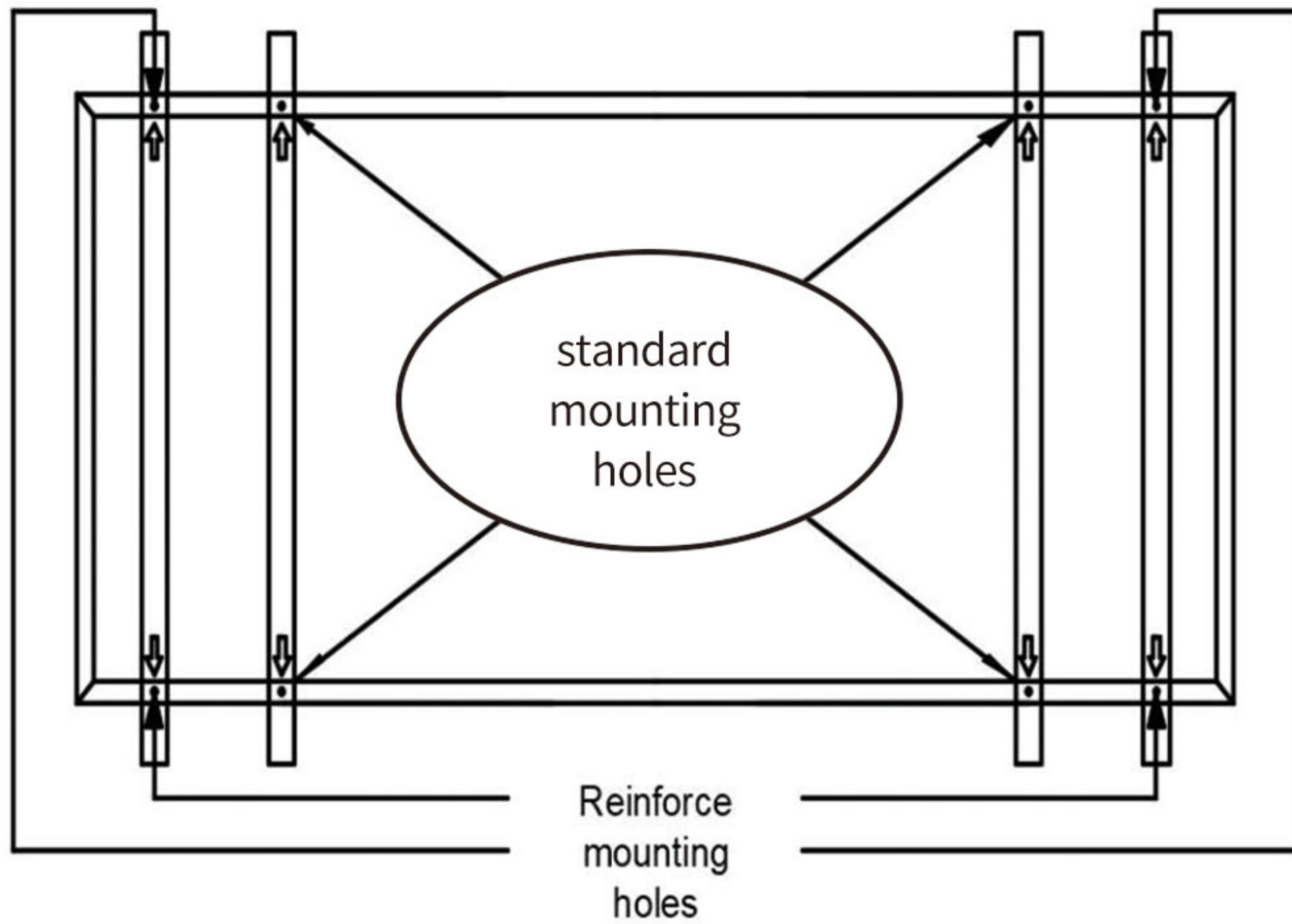
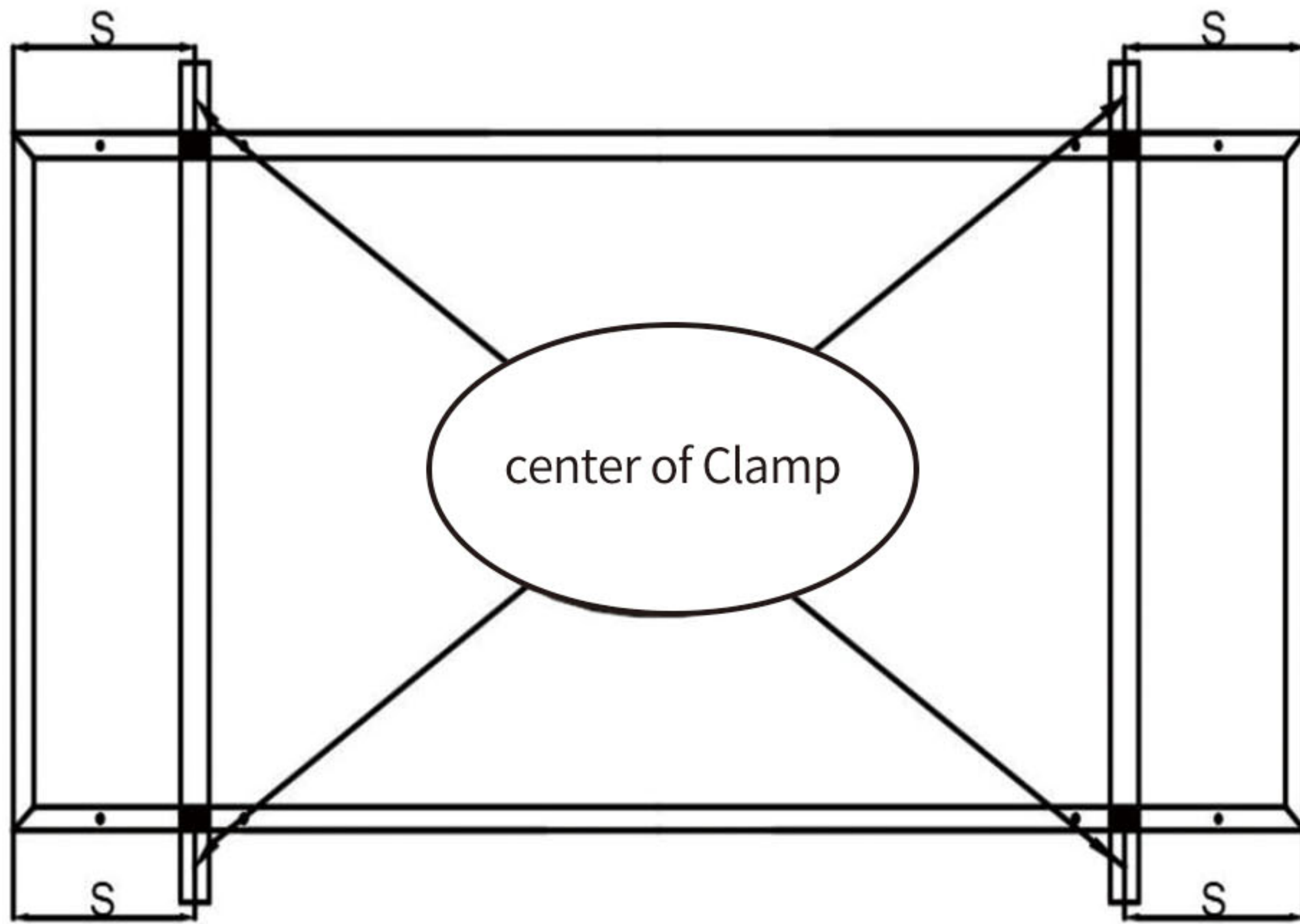
Installation	Mounting System	Clamping System
	Maximum Load: Uplift load \leq 2400 Pa Downforce load \leq 5400 Pa	Maximum Load: Uplift load \leq 2400 Pa Downforce load \leq 5400 Pa
	Use standard mounting holes and reinforce mounting holes	Use four clamps 520mm<S<620mm ■ Permissible Clamp Range
	 <p style="text-align: center;">standard mounting holes</p> <p style="text-align: center;">Reinforce mounting holes</p>	 <p style="text-align: center;">center of Clamp</p>
	The guide rail should be installed parallel position to the long side of the frame	The guide rail should be installed perpendicular to the long side of the frame

TG Mono-N-Type module (182mm)	
Type	PSXXM7GFH-24/TNH; PSXXM7GF-24/TNH
Size (mm)	2278mm × 1134mm × 35mm; 2274mm × 1134mm × 35mm

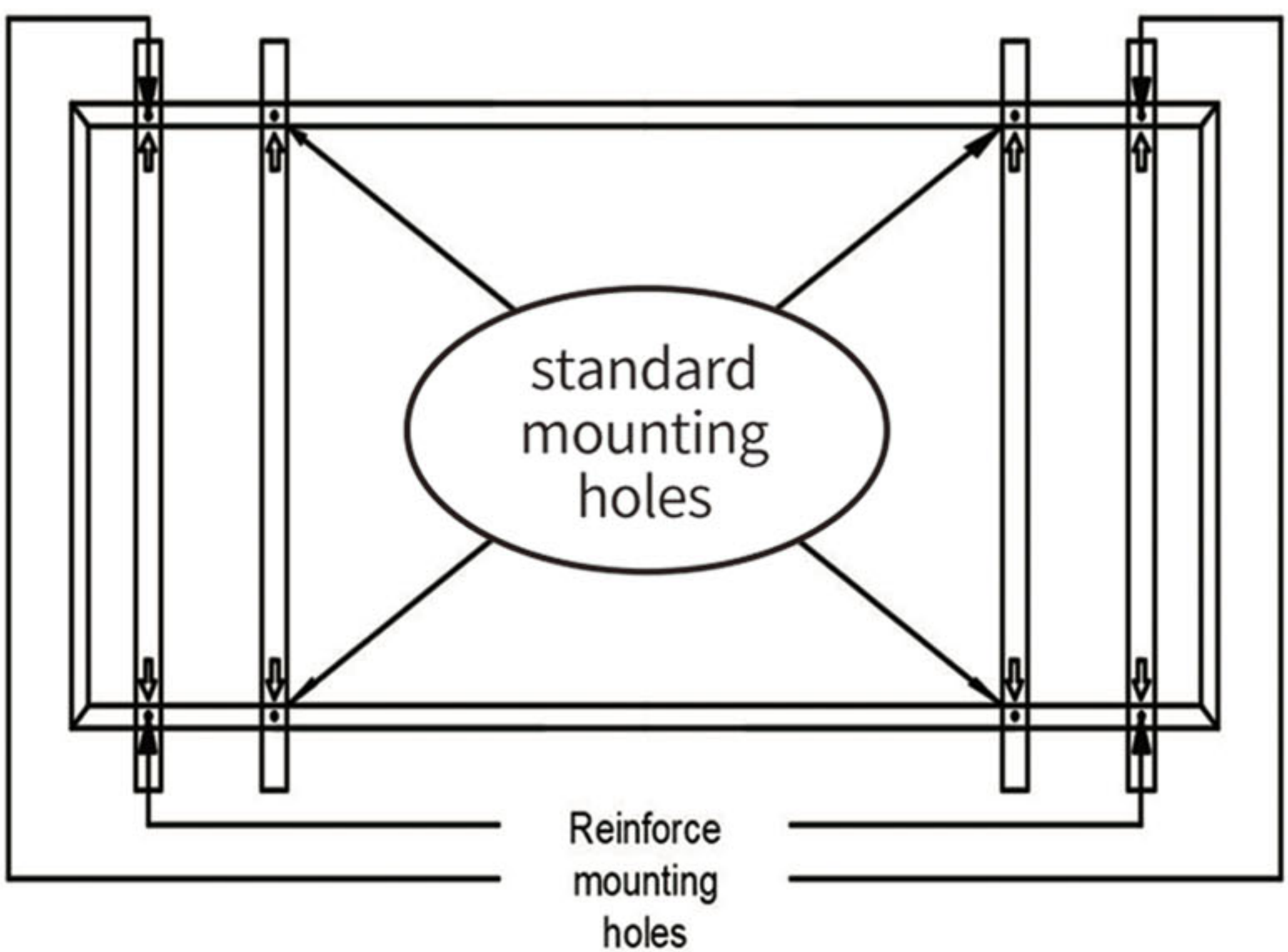
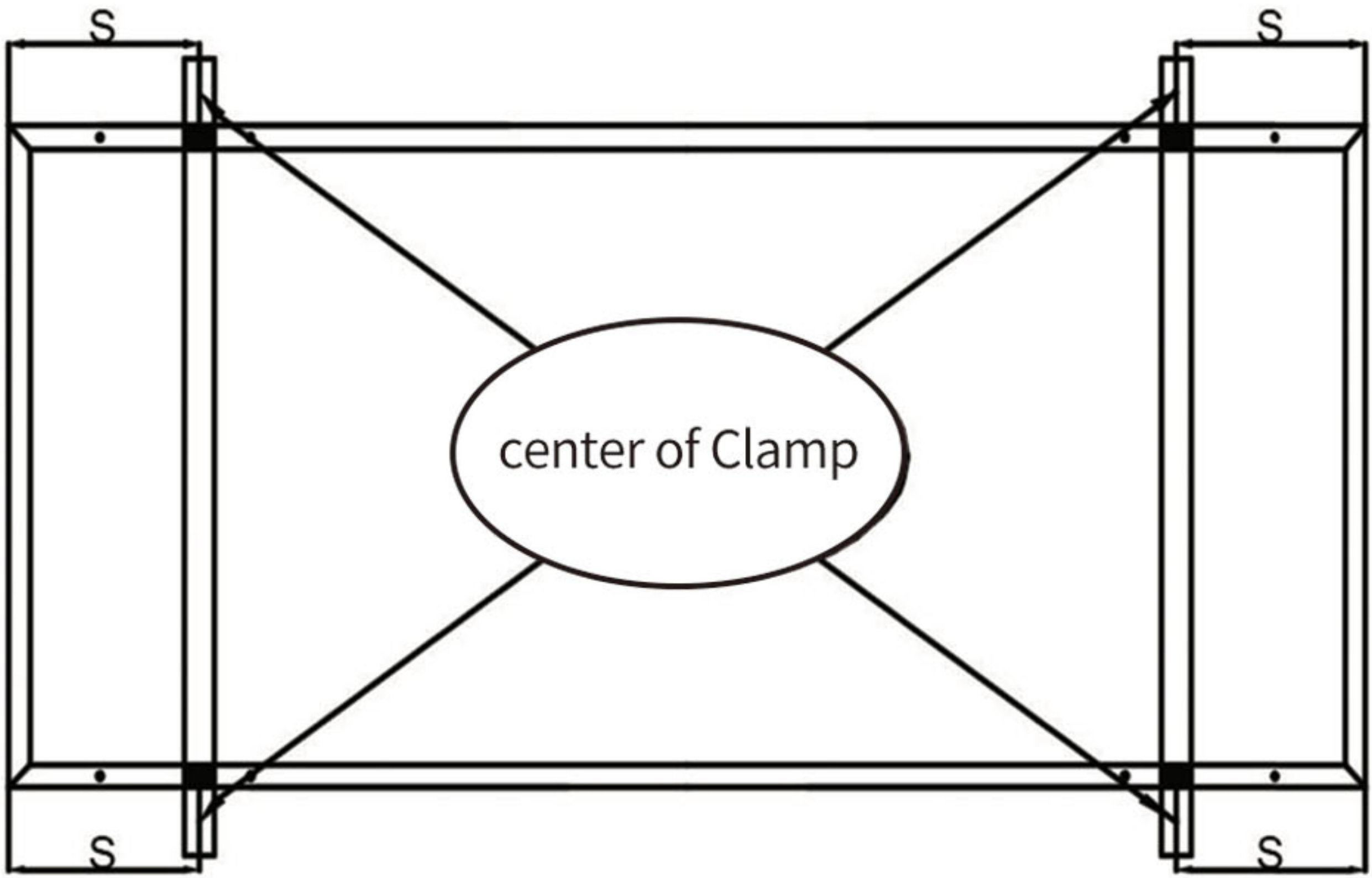
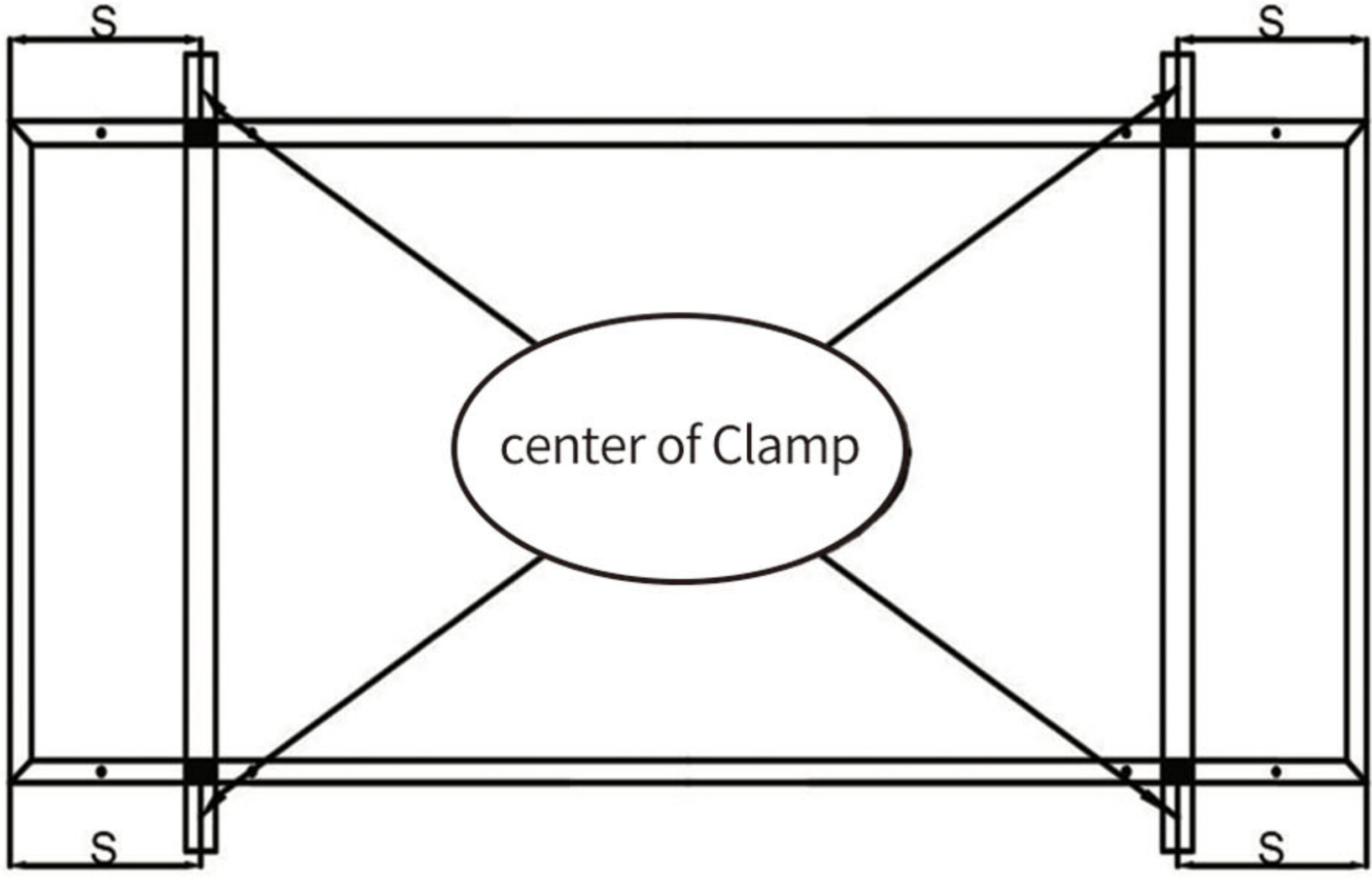
Installation	Mounting System	Clamping System	
	Maximum Load: Uplift load \leq 2400 Pa Downforce load \leq 5400 Pa	Maximum Load: Uplift load \leq 2400 Pa Downforce load \leq 2400 Pa	Maximum Load: Uplift load \leq 2400 Pa Downforce load \leq 5400 Pa
	Use standard mounting holes and reinforce mounting holes	Use four clamps 500 mm < S < 600mm ■ Permissible Clamp Range	Use four clamps 400mm < S < 500mm ■ Permissible Clamp Range
			
	The guide rail should be installed perpendicular to the long side of the frame	The guide rail should be installed perpendicular to the long side of the frame	The guide rail should be installed perpendicular to the long side of the frame

Warning: Do not attempt to drill holes in the module frame or in the glass surface of the module. Any such modifications will void the PHONO SOLAR product warranty.

- 3.4 When installing a module on a pole ensure that the pole and mounting rail can withstand anticipated local winds. The pole must be installed on a secure base.
- 3.5 Ensure that the installation height is such that the lowest modules will not be covered by accumulated snow or shaded by the surroundings.
- 3.6 Ensure that there is adequate ventilation under the modules, conforming to local, regional and state standards and regulations.
- 3.7 A minimum distance of 10cm, between the roof plane and the frame of the module is generally recommended.
- 3.8 Observe the linear thermal expansion of the module frames. A minimum distance of 1cm between two modules is generally recommended.

4 ELECTRICAL INSTALLATION

(Note: All instructions hereafter are for reference only. A licensed/qualified person or installer must be responsible for the design, installation, mechanical load calculation and security of the photovoltaic system.)

- 4.1 Any hardware used must be compatible with the mounting material to avoid galvanic corrosion.
- 4.2 Only use connectors that are designed for photovoltaic systems and that match PHONO SOLAR modules.
- 4.3 When working with the connectors only use tools as recommended by the connector manufacturer.
- 4.4 PHONO SOLAR recommends that the same type of modules are connected together in order to avoid any system power loss.
- 4.5 The maximum number of series connected modules depends on system design, the type of inverter used and environmental conditions.

- 4.6 Select insulated cables that are able to resist to ultraviolet radiation and extreme weather conditions.
- 4.7 The rated voltage of the cable chosen must be appropriate to the overall maximum voltage of the system.
- 4.8 The module frame may be grounded according to local, regional and state safety and electrical standards. Ensure that a recommended connector or equivalent is used for the grounding cable. The grounding cable must be properly fastened to the module frame.
- 4.9 In order to reduce the risk of potential induced degradation (PID), Phono Solar strongly recommends to use anti-PID solar modules in wet regions (i.e. shores, wetlands), or to use the system negative grounding where the negative polarity of the PV modules array (i.e. negative grounding at the DC bus bar level) is connected to the ground. Failure to comply with this recommendation may reduce the module performance and will invalidate the limited power warranty of the module.
- 4.10 Voltages are additive when modules are connected directly in series, and modules currents are additive when modules are connected in parallel, as illustrated in Figure 3. Modules with different electrical characteristics must not be connected directly in series.

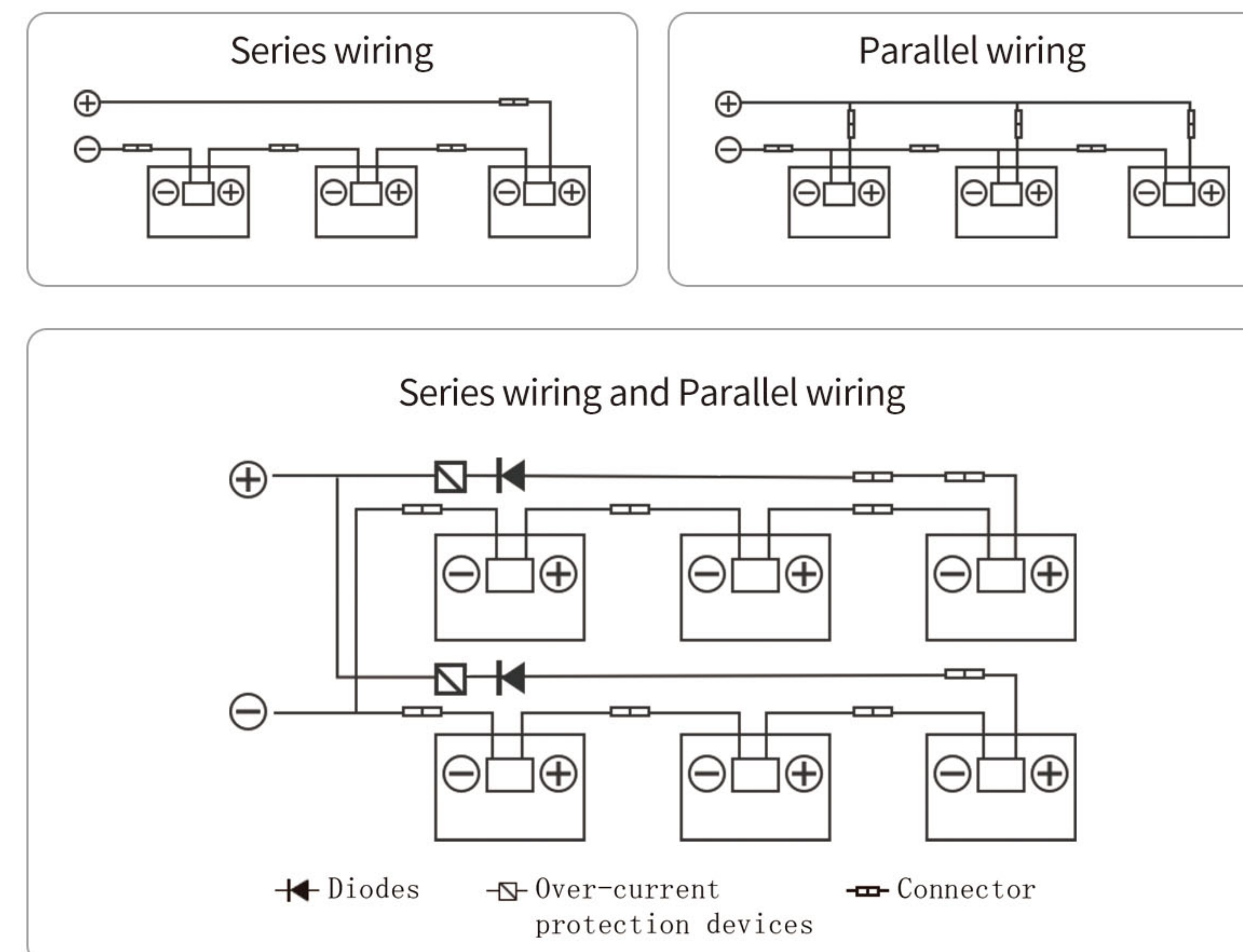

Figure 3

5 GROUNDING

5.1 For grounding and bonding requirements, please refer to regional and national safety and electricity standards. If grounding is required, use a recommended connector type for the grounding wire.

5.2 For grounding, this guide refers to module frame grounding. If grounding is required, make sure module frames (metal exposed to touch) are always grounded.

5.3 System grounding is not mandatory for Phono Solar modules, however negative system grounding may be required by local authorities and can therefore be recommended.

5.4 Phono Solar recommends the Grounding Clip (Cat.No.1954381 (Supplier: TE)) when grounding.

5.5 The grounding lug must be a tin-coated copper lug, silver in color. Do NOT use a bare copper lug, which is brown.

Please refer to relevant connector specifications for instructions

For grounding clip, using a cross-recessed screwdriver, thread the screw into the hole until the head is flush with the base and the base is flush with the frame, then tighten the screw with another 1/4 to 1/2 turn. Insert the wire into the wire slot. Press down on both ends of the wire (the wire slot will cause the wire to form a slight curve).

Manually, or using channel lock pliers, push the slider over the base until it covers the base. This will terminate the wire.

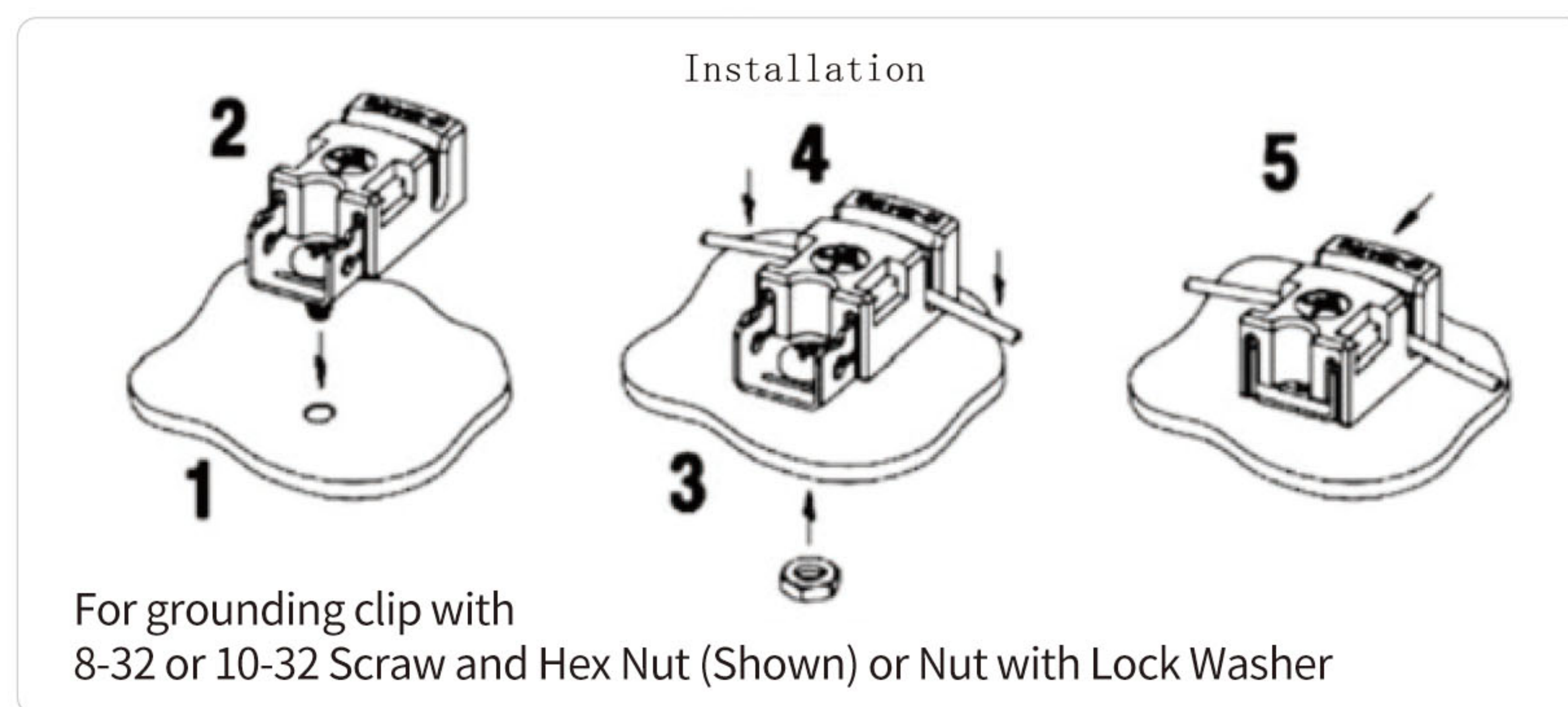

Figure 4

6 MAINTENANCE

6.1 The amount of electricity generated by a solar module is proportionally correlated with the light absorbed by the module with a factor equivalent to module conversion efficiency. Cells shaded by leaves and dust accumulated on the surface will reduce the light absorption and power generation, and therefore it is important to keep modules unshaded and clean. To ensure the optimum module performance, PHONO SOLAR recommends the following:

- PV modules can be cleaned only if the solar irradiance is below 200W/m²; Cleaning water or solution with a large temperature difference from the modules shall not be used for cleaning the modules.
- It is forbidden to clean PV modules under the weather conditions of heavy rain, heavy snow or wind grade higher than 4.
- If pressurized water is employed in cleaning, the water pressure applied on the glass surface of the module shall not exceed 4MPa (40bar); the module is prohibited to bear the extra force.
- When cleaning PV modules, do NOT step on the modules; do NOT spray water on the backside of the module or the cables; keep the connectors clean and dry; prevent fire and electrical shock from occurring; do NOT use a steam cleaner.
- When cleaning the modules, use soft cloth and clean water together with a mild detergent. The temperature of the water applied shall be close to that of the module being cleaned.
- Use dry or wet soft clean cloth to clean the PV modules; Corrosive solvents hard objects are strictly prohibited.
- If there are greasy dirt and other substances on the surface of the PV module which are difficult to clean, conventional household glass cleaning agents can be used.
- Do NOT use the alkaline and strong acid solvents.
- PHONO SOLAR recommends a minimum tilt angle of 10 degrees for performance and self-cleaning purposes. If the installer chooses to install at an inclination <10 degrees they should make the end user aware that more regular cleaning of the panels will be required to avoid the accumulation of dust and debris.
- The back surface of the module normally does not need to be cleaned, but in the event this is deemed necessary, avoid the use of any sharp objects that might damage or penetrate the substrate material.
- Check the electrical and mechanical connections routinely and make sure they are clean, safe, complete and secure.
- In the event of a problem, please consult with a licensed/qualified person.

6.2 Requirements for Water Quality

- PH: 5~7
- Chloride and Salinity: 0 - 3,000 mg/L
- Turbidity: 0-30 NTU
- Conductivity: 1500~3000 $\mu\text{s}/\text{cm}$
- Total dissolved solids (TDS): ≤ 1000 mg/L
- Water Hardness—calcium and magnesium ions: 0-40 mg/L
- Non-alkaline water must be used; demineralized water shall be used if the condition permits

6.3 Safety Warning

- Cleaning work might impose the risk of damaging the a component or a series of components, and might also increase the risk of electric shock.
- Broken or damaged components may present a risk of electric shock due to current leakage, and this risk may be exacerbated by the moisture in the components. Before cleaning, ensure to check all wiring for possible rodent damage, weathering and that all connections are tight and corrosion free.
- During the day, the voltage and current present in the array are sufficient to cause a fatal electric shock. Before cleaning, make sure the array is disconnected from live parts (such as inverters, etc.).
- Wear protective equipment (clothes, insulated gloves, etc.) while cleaning.
- Do not immerse components partially or completely in water or any kind of liquid.

7 DISCLAIMER OF LIABILITY

Since it is impossible for PHONO SOLAR to control installation, operation, application and maintenance of the photovoltaic system according to this instruction, PHONO SOLAR does not accept responsibility and expressly disclaims liability for any loss, damage, or expense arising out of or in any way connected with such installation, operation, use or maintenance.

PHONO SOLAR will not take any responsibilities for any possible violation of patent rights and third party rights that are related to application of the solar energy system. No permission of patents is given through implication.

The information of this instruction is from knowledge and experience of PHONO SOLAR, and so it is reliable. However, the instructions and suggestions of this instruction do not make an external or internal of guarantee. PHONO SOLAR reserves the right to revise this instruction, products and all the information about products without prior notification to customers.

Failure of the customer to follow the requirements outlined in this Manual during the installation of the module will result in the invalidity of the PHONO SOLAR product warranty.

8 DISPOSAL OF END OF LIFE PRODUCTS

Phono Solar is a member of PV CYCLE, a European non-profit association managing a collection and recycling scheme for end-of-life solar modules throughout Europe. Please visit the website: <http://www.pvcycle.org/> for further information.

PHONO

Phono Solar Technology Co., Ltd.

Address : No. 1 Xinghuo Rd., Nanjing Hi-tech Zone, Nanjing, China

Tel: +86 25 5863 8000 Fax: +86 25 5863 8009

E-mail: info@phonosolar.com

Website: www.phonosolar.com

